

Country Lane Two Drawer Nightstand

Style # 961-810 (Vintage White) DPCI # 074-05-0483 (Carysbrook)

Assembly Instructions

CONGRATULATIONS

You've purchased a fine furniture product by



All of our easy-to-assembly furniture is solidly built and rigorously tested to ensure years of enjoyment.

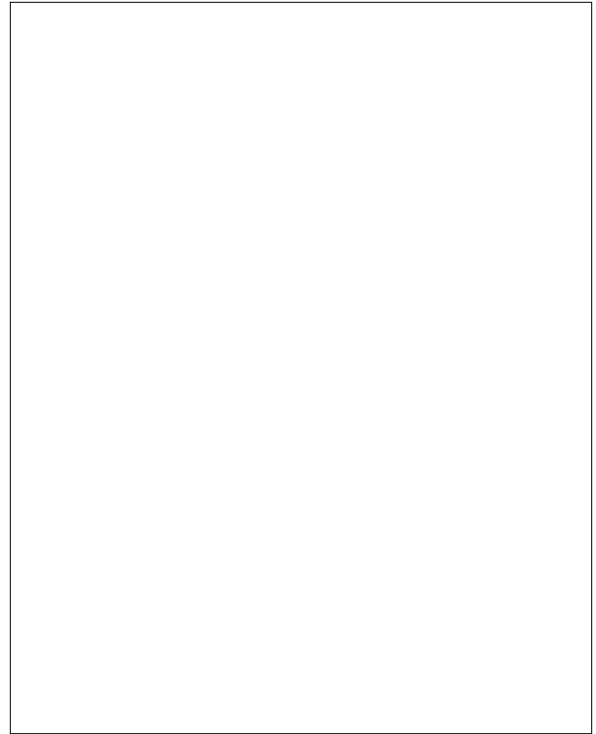

BEFORE YOU BEGIN

You may find it helpful to have a helper while assembling unit.

We've included easy to follow step-by-step instructions which have been carefully written to ensure quick, easy assembly of your furniture. Be sure to read the instructions (a time saver in the long run).

Identify all parts and hardware. If any pieces are missing call **Toll Free number 1-800-782-3876** or you may **e-mail CISupport@Thomasville.com** for replacement parts. For faster service, have the style number handy when calling.

Questions?

We're here to help. You may e-mail CISupport@Thomasville.com or call 1-800-782-3876 between 8:00a.m. - 9:00p.m., Monday - Friday and 9:00a.m. - 5:00p.m., Saturday (Eastern Time). Holiday weekends will not be staffed. For faster service, have the style number handy when calling.

Tools

You will need a standard flat-head screwdriver, Phillips head screwdriver and a hammer.

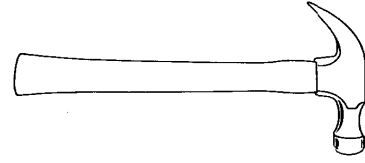

Parts List

Screws are shown actual size. Hardware may be shown smaller than actual size. Before you begin assembly, lay all pieces out on the floor according to these illustrations.

Note: For reasons of manufacturing efficiencies, you may find extra hardware and unused holes in parts.

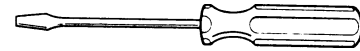

S2 1/2" Phillips-head Screw (16)
002262



CS Long Cam Stud (12)
009612

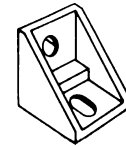

LB Plastic L-Bracket (4)
001136



S3 1/2" Flat Head Screws (24)
009686



SCS Short Cam Stud (8)
009611



CH Cam Housing (20)
009613

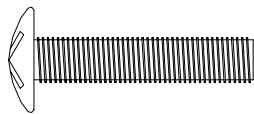

7/8" Hardware Bolt (2)
001092



Cover-cap (5)
80071424



Knob (2)
80071425

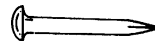

Nail (25)
002669



Glue
004821

Note: All parts may not be identified with labels, but to help identify certain parts, you may see one or more types of labelling. One type is the peel-off label and the other is an ink-print on one of the unfinished edges.

Drawer Guides

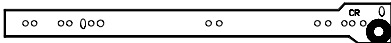

007489 (2) stamped "CR"

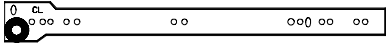

007488 (2) stamped "CL"

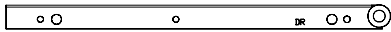

007491 (2) stamped "DR"

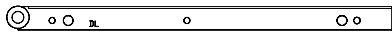

007490 (2) stamped "DL"

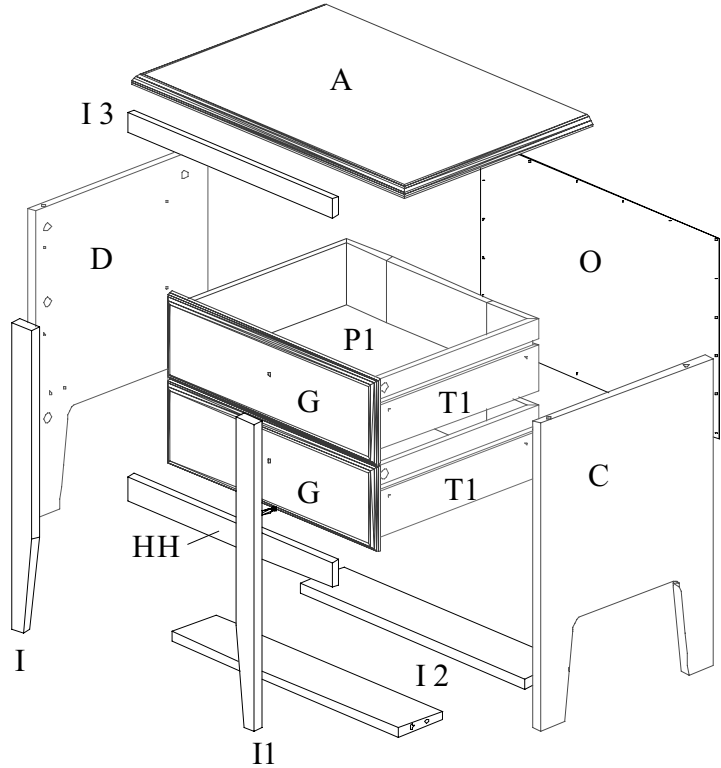

G Drawer (2)
18-1/8" x 6-1/16"
071911LA

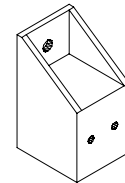

GS Guide Spacer (8)
80052581

T1 Drawer Sides (2)
44" x 4-5/8"
204606M

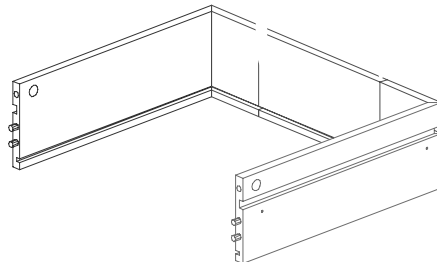

P1 Drawer Bottom (2)
16-1/16" x 13-9/16"
80101361

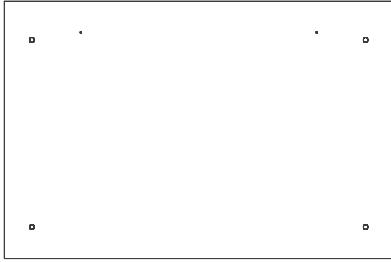

A Top (1)
23-7/16" x 15-9/16"
012406LA

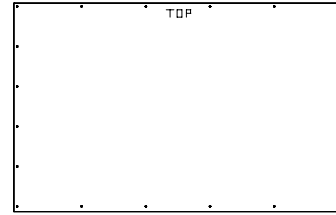

O Back Panel (1)
20-11/16" x 14-1/4"
80073166

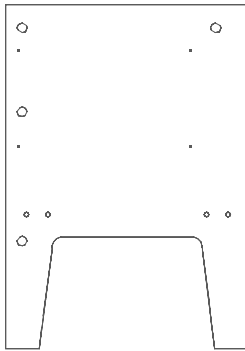

D Left Side (1)
20-3/8" x 14-3/16"
042016LA

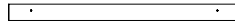

I 3 Top Front Rail (1)
17-3/4" x 1-1/4"
091809LA

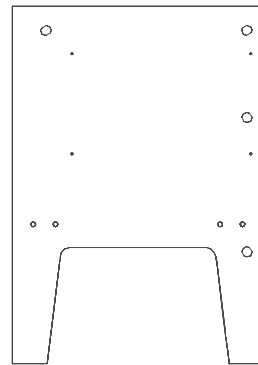

C Right Side (1)
20-3/8" x 14-3/16"
032016LA



HH Bottom Front Rail (1)
17-3/4" x 1-5/8"
091811LA



I Left Vertical Rail (1)
20-5/16" x 1-5/8"
092012LA

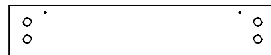

I 2 Bottom Rail (2)
19-5/8" x 3-5/8"
092009H



I 1 Right Vertical Rail (1)
20-5/16" x 1-5/8"
092011LA

1

Parts needed for this step:

Drawer Front (G).

Hardware needed for this step:

(2) Short Cam Studs (SCS), Glue.

Action Required:

- * Place drawer front (G) on the floor with holes facing up, as shown.
- * Screw (2) **short** cam studs (SCS) into the holes, as shown, in drawer front (G).
- * Apply 3-4 drops of glue into the four dowel holes in drawer front, but do not fill with glue.
- * Spread glue evenly on the inside of the holes with a toothpick or similar object.
- * Set aside.

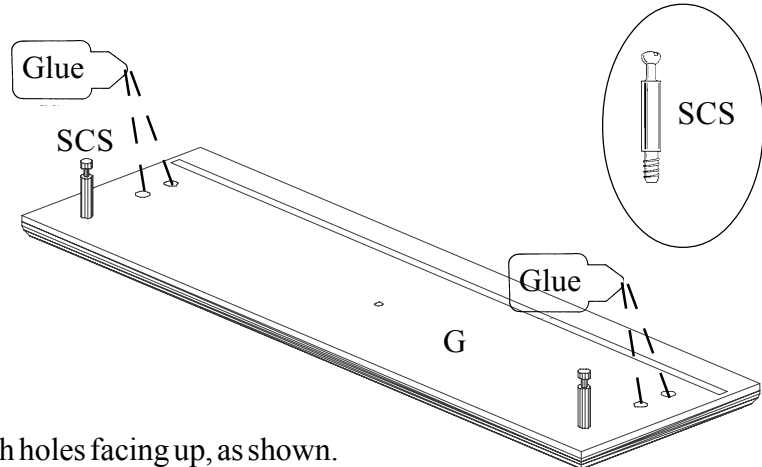

2

Handle Drawer Sides with Care

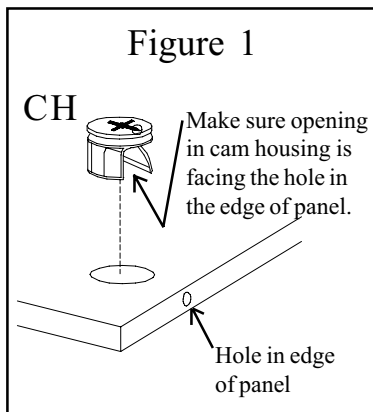

Parts needed for this step:

Drawer Sides (T1), Drawer Bottom (P1).

Hardware needed for this step:

(2) Cam Housings (CH), Glue.

Action Required:

- * Place drawer sides (T1) as shown in diagram.
- * **SEE FIGURE 1...** Insert (2) cam housings (CH) into the holes, as shown, in drawer sides (T1). **Press with thumb to fully seat cam housings.**
- * Apply glue into the corner joints of drawer sides (T1).
- * Stand drawer bottom (P1) in long groove, **finished side up**, and fold the drawer sides (T1) up around the drawer bottom (P1).

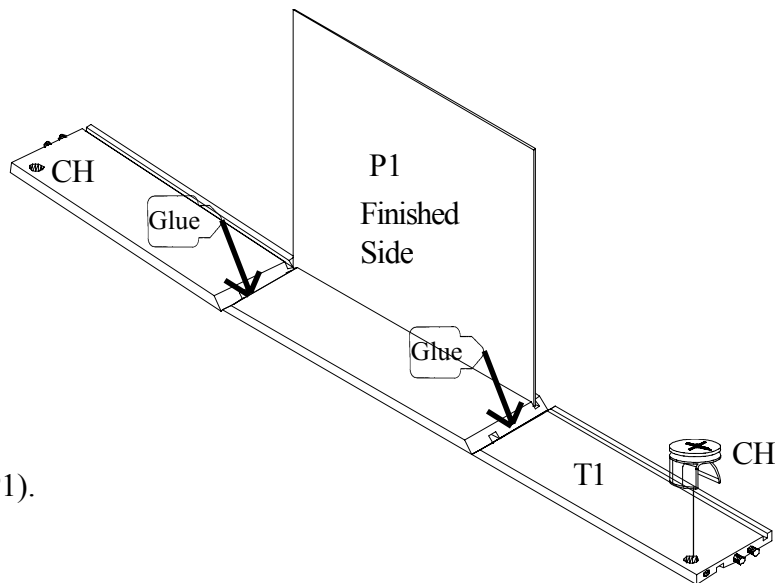

3

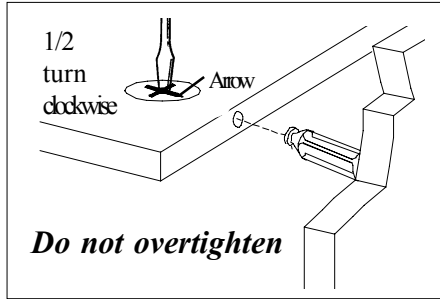

Parts needed for this step:

Drawer Front (G), Drawer Sides (T1),
Drawer Bottom (P1).

Hardware needed for this step:

Standard Flat-Head Screwdriver.

Action Required:

- * Place the dowels in the drawer sides (T1) into the holes in drawer front (G). Note Cam studs should align with holes in drawer sides (T1).
- * Press down on the back of the drawer. If necessary, tap on drawer sides (T1), using a hammer against a block of wood wrapped in a protective cloth.

Note: Make sure drawer bottom inserts into drawer front groove.

* Wipe off excess glue with a damp cloth.

* Lock cam housings with a half turn clockwise of a standard flat-head screwdriver.

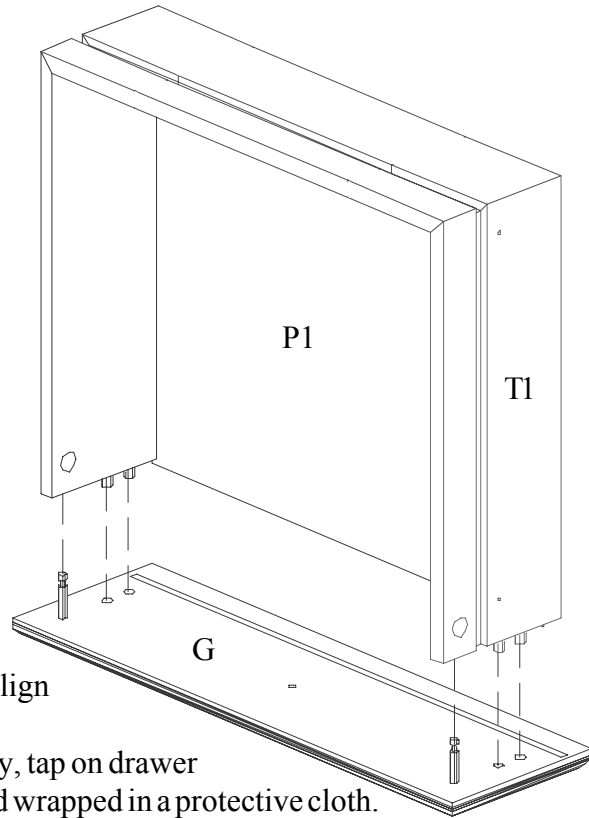

4

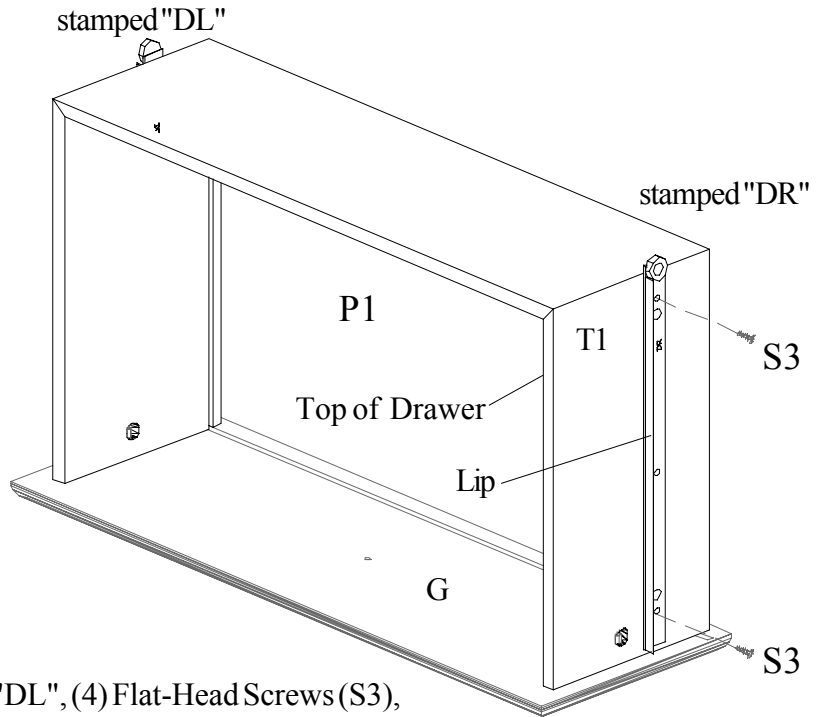
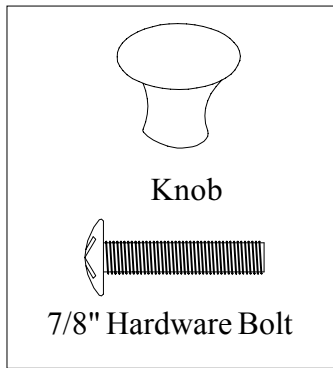

Parts needed for this step:
Drawer Assembly (G, T1 & P1).

Hardware needed for this step:
Drawer Guides stamped "DR" and "DL", (4) Flat-Head Screws (S3),
Knob, Round-Head 7/8" Hardware Bolt.

Action Required:

Note: There is a right drawer guide (stamped "DR") and a left drawer guide (stamped "DL").

* Attach drawer guides to drawer sides (T1), with rollers facing toward the back, using (2) flat-head screws (S3) in each drawer guide. The drawer guides have a lip on one edge. The lip goes toward the top of the drawer, as shown.

* Attach knob to drawer (G), using round-head 7/8" hardware bolt.

Follow Steps 1-4 for remaining Drawer (G).

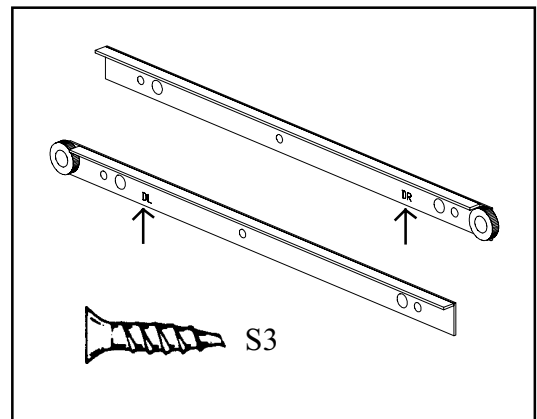

5

Parts needed for this step:

Left Vertical Rail (I), Right Vertical Rail (I1).

Hardware needed for this step:

(4) **Short** Cam Studs (SCS).

Action Required:

* Screw (4) **short** cam studs (SCS) into each of the holes, as shown, in left and right vertical rails (I & I1).

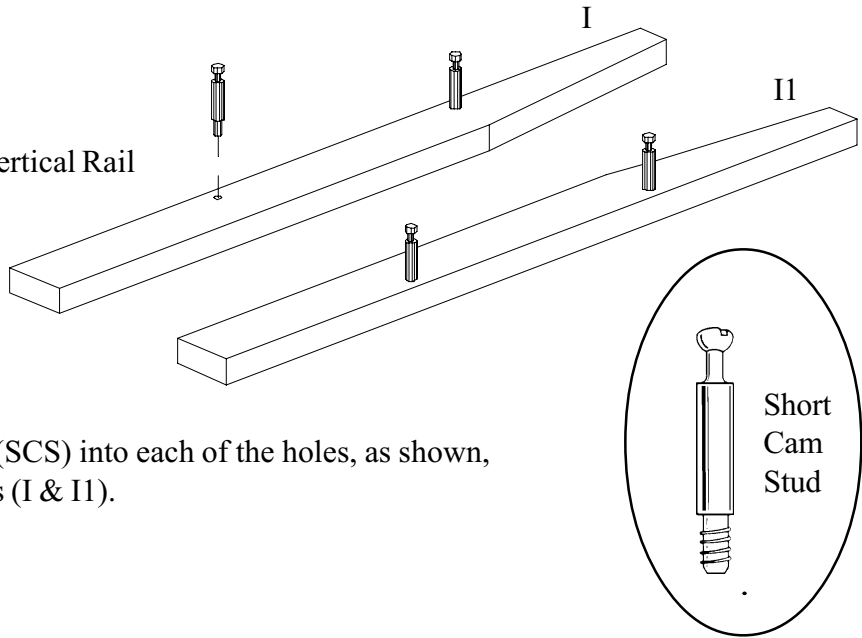

6

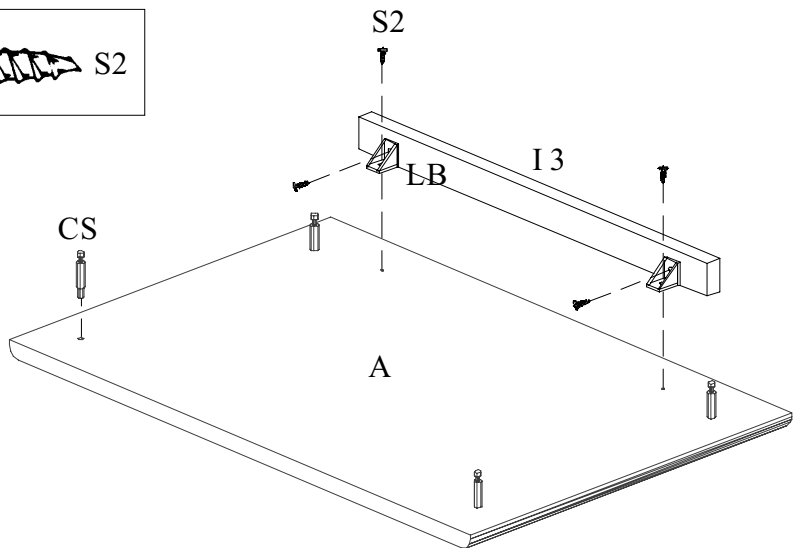
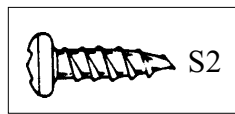
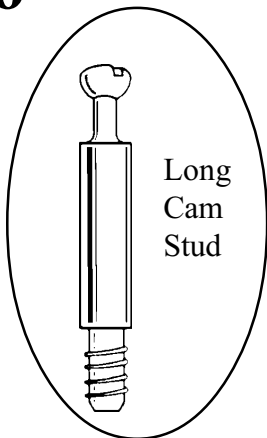

Parts needed for this step:

Top (A), Top Front Rail (I3).

Hardware needed for this step:

(2) L-Brackets (LB), (4) Round-Head Screws (S2), (4) **Long** Cam Studs (CS).

Action Required:

- * Align the holes in rail (I3) with the holes in top (A) for proper placement of L-brackets (LB).
- * Attach (2) L-brackets (LB) to rail (I3), using (2) round-head screws (S2).
- * **Loosely**, attach rail (I3) to top (A), using (2) round-head screws (S2).
- * Screw (4) **long** cam studs (CS) into the holes, as shown, in top (A).

7

Parts needed for this step:

(2) Bottom Rails (I 2), Bottom Front Rail (HH).

Hardware needed for this step:

(2) L-Brackets (LB),
 (4) Round-Head Screws (S2),
 (8) Cam Housings (CH).

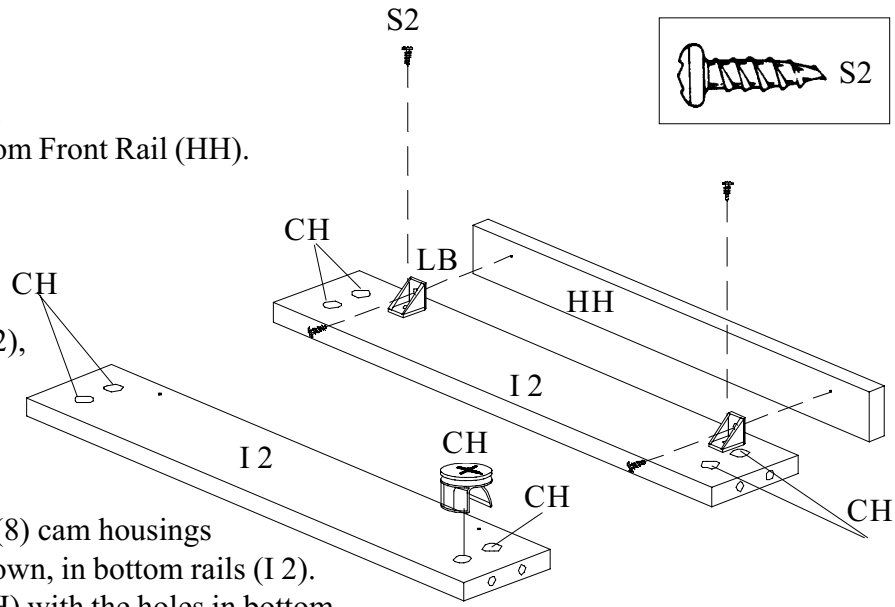

Action Required:

- * **SEE FIGURE 1**...Insert (8) cam housings (CH) into the holes, as shown, in bottom rails (I 2).
- * Align the holes in rail (HH) with the holes in bottom rail (I 2) for proper placement of L-brackets (LB).
- Note: There is only one bottom front rail (HH) attached to bottom rail (I 2).**
- * Attach (2) L-brackets (LB) to bottom rail (I 2), as shown, using (2) round-head screws (S2).
- * **Loosely**, attach rail (HH) to bottom rail (I 2), using (2) round-head screws (S2). **Note: Holes are not used in the other bottom rail (I 2).**

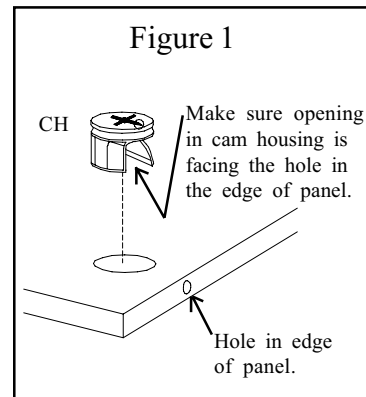

8

Parts needed for this step:

Left Side (D), Right Side (C).

Hardware needed for this step:

(8) Cam Housings (CH), (8) Cam Studs (CS).

Action Required:

- * **SEE FIGURE 1**...Insert (8) cam housings (CH) into the holes, as shown, in left and right sides (D & C).
- * Screw (8) cam studs (CS) into the holes, as shown, in left and right sides (D & C).

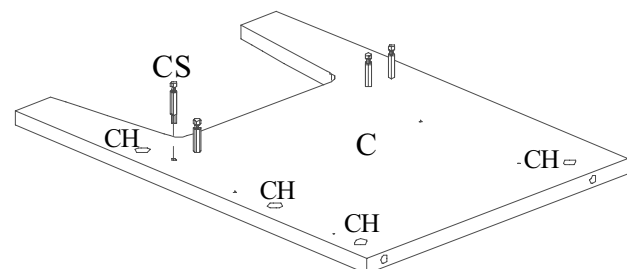
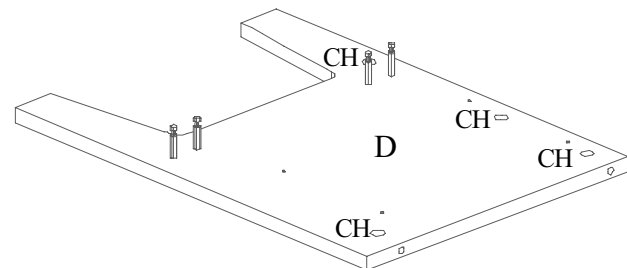

9

Parts needed for this step:
Left Side (D), Right Side (C).

Hardware needed for this step:
(8) Guide Spacer (GS), (8) Round-Head Screws (S2).

Action Required:

* **Securely**, attach (8) guide spacers (GS) to left and right sides (D & C), as shown, using (8) round-head screws (S2).

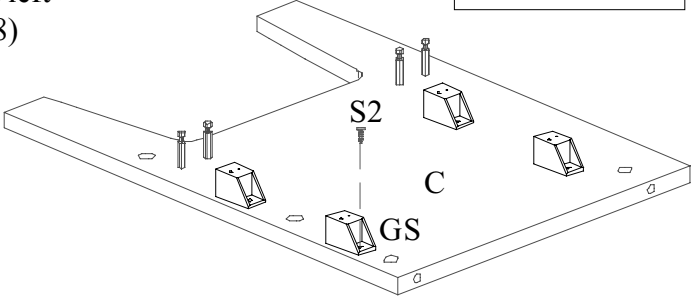
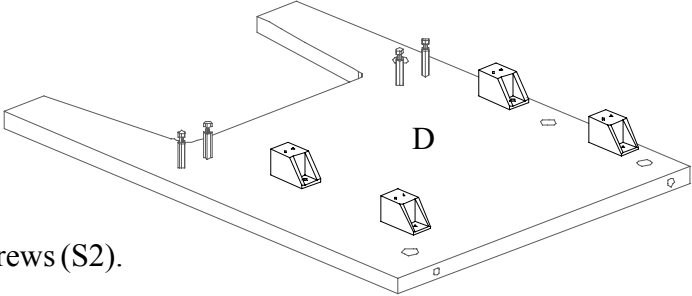

10

Helpful Hint...

Hold guide spacers with one hand while attaching drawer guides to prevent spacers from rotating.

Figure 2

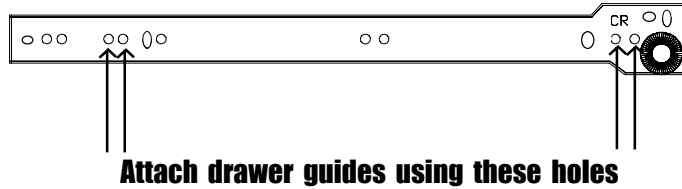

Parts needed for this step:

Left Side (D), Right Side (C).

Hardware needed for this step:

(4) Drawer Guides (stamped "CL" and "CR"),
(16) Flat-Head Screws (S3).

Action Required:

Note: There is a left and a right drawer guide. The guides stamped "CL" will be attached to left side (D) and the guides stamped "CR" will be attached to right side (C).

* SEE FIGURE 2...

AND HELPFUL HINT...attach drawer guides to guide spacers (GS), using (4) flat-head screws (S3) in each guide.

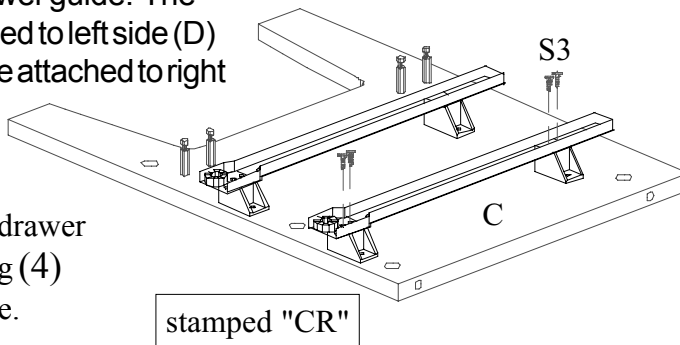
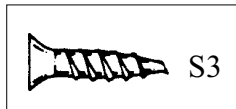
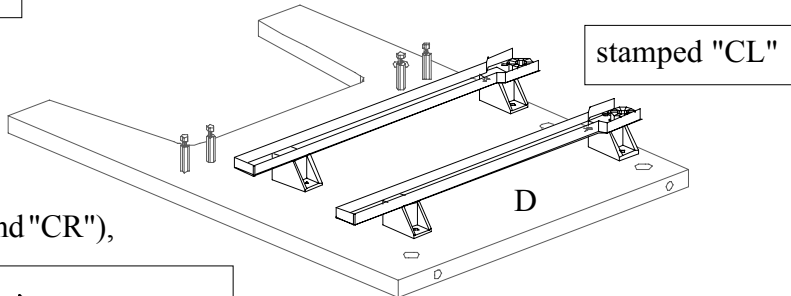

11

Parts needed for this step:

Left Side (D), Right Side (C),
(2) Bottom Rails (I 2).

Hardware needed for this step:

Standard Flat-Head Screwdriver.

Action Required:

- * Place left side (D) on its back edge, as shown.

Note: Small holes in the lower bottom rail (I 2) should be up, as shown.

- * Attach bottom rails (I 2) to left side (D).
- * Lock cam housings with a half turn clockwise of a standard flat-head screwdriver. DO NOT OVER-TIGHTEN.
- * Attach right side (C) to bottom rails (I 2).
- * Lock cam housings. DO NOT OVER-TIGHTEN.

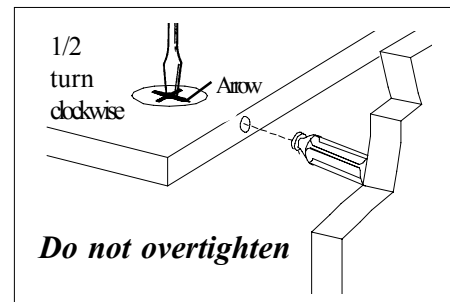
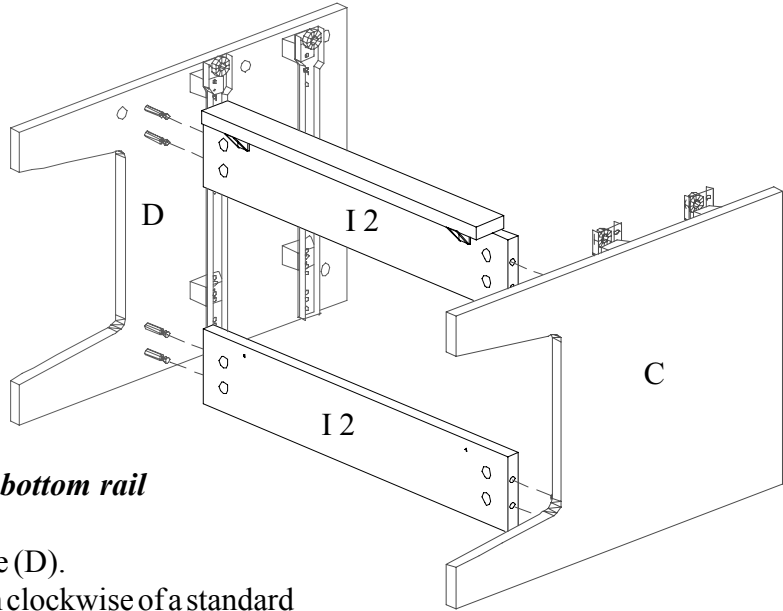

12

Parts needed for this step:

Top (A).

Hardware needed for this step:

Standard Flat-Head Screwdriver.

Action Required:

- * Attach top (A) to left and right sides (D & C).
- * Lock cam housings with a half turn clockwise of a standard flat-head screwdriver. **NO NOT OVER-TIGHTEN**

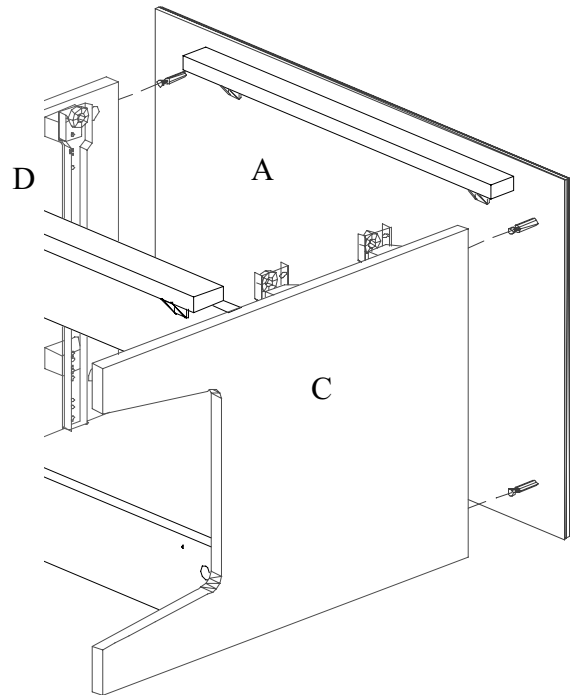

13

Parts needed for this step:

Left Vertical Rail (I),
Right Vertical Rail (I1).

Hardware needed for this step:

Standard Flat-Head Screwdriver.

Action Required:

- * Place left vertical rail (I) to left side (D).
- * Place right vertical rail (I1) to right side (C).
- * Lock cam housings.

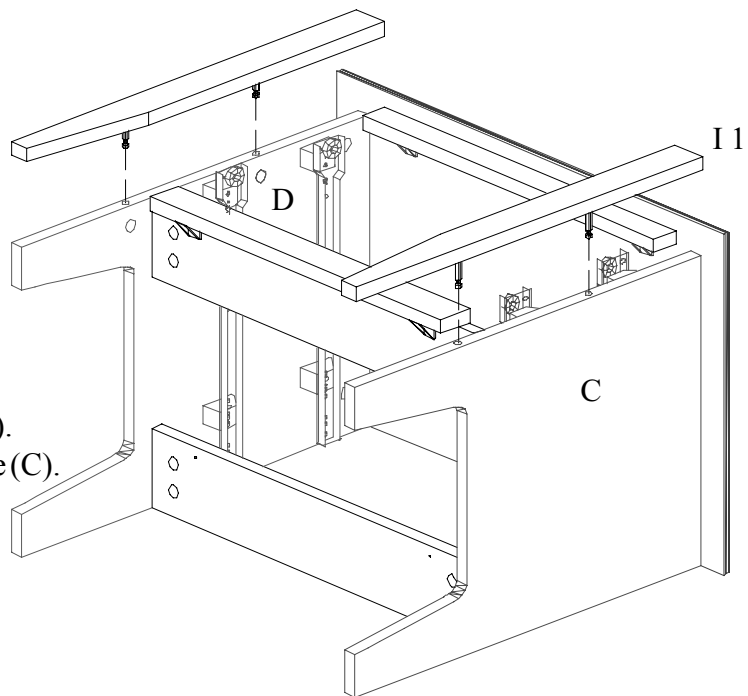

14

Hardware needed for this step:

Phillips-Head Screwdriver.

Action Required:

- * Tighten screws in L-Brackets in top (A) and bottom rail (I 2).

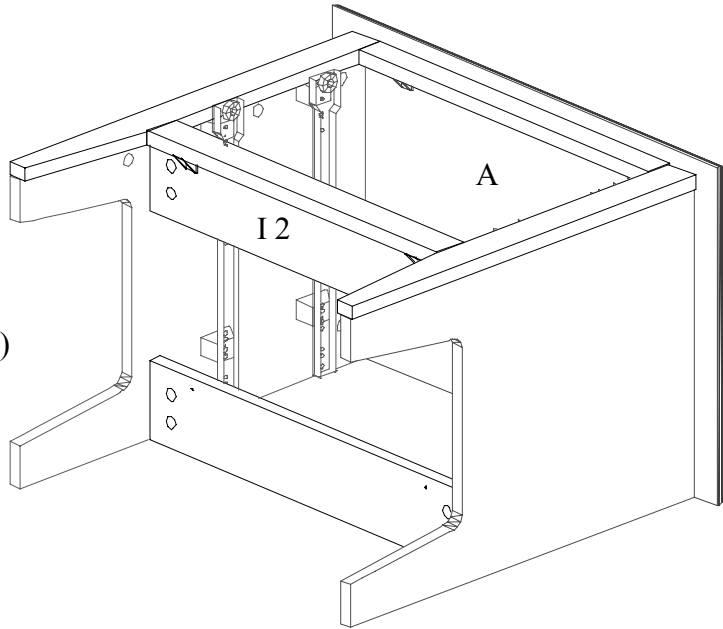

15

Parts needed for this step: Back Panel (O), Top

Hardware needed for this step: Nails.

Action Required:

- * With a helper, carefully turn case over with the front against the floor.
- * Position back panel (O) even with the bottom edge of bottom rail (I 2).
- * Make sure panel (O) fits square and even side to side. **If it doesn't, adjust unit into square by pushing or pulling on one corner of the unit until back panel fits squarely.**
- * While nailing into pilot holes, take care to hammer nails in straight.

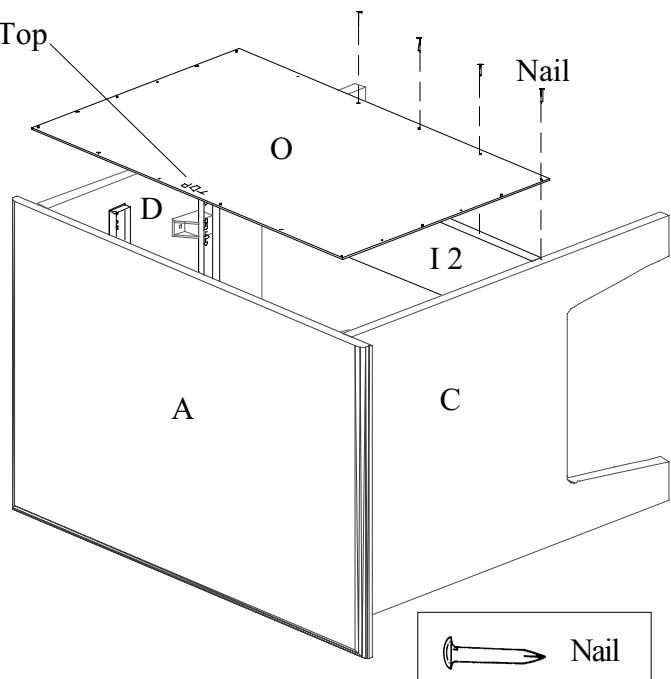

Note: Back panel adds stability to case.

Note: Make sure all cam housings are in the locked position.

16

- * Stand case in its upright position.
- * Install the drawers.

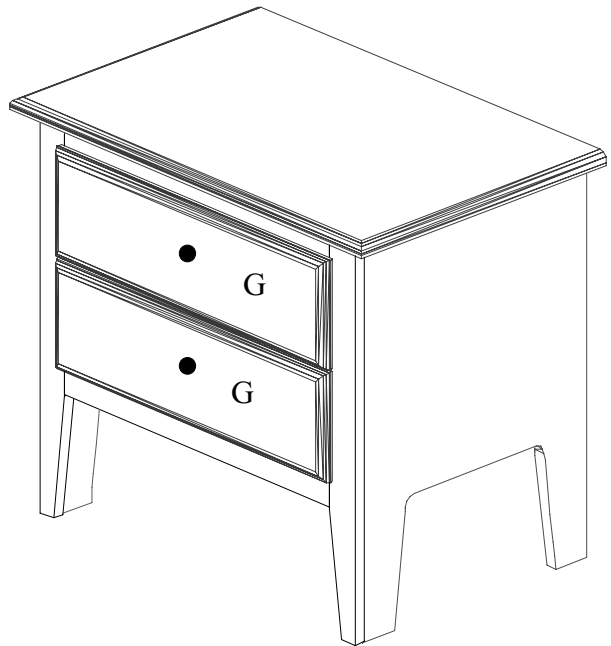

17

- * Decorative cover caps are provided to cover exposed cam housings.

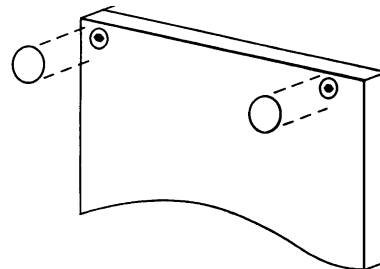

That's it! You've finished assembling your Two Drawer Nightstand by

RENOVATIONS
a division of
Thomasville Furniture

MRP- 80101403 (Carysbrook)
1203