

# Country Lane Armoire

Style # 563-340 ( Pine) DPCI# 074-09-0702

## Assembly Instructions

### CONGRATULATIONS

You've purchased a fine furniture product by



All of our easy-to-assembly furniture is solidly built and rigorously tested to ensure years of enjoyment.

We're here to help. Just call **1-800-782-3876** or e-mail **CISupport@Thomasville.com**

### BEFORE YOU BEGIN

You may find it helpful to have a helper while assembling unit.

We've included easy to follow step-by-step instructions which have been carefully written to ensure quick, easy assembly of your furniture. Be sure to read the instructions (a time saver in the long run).

Identify all parts and hardware. If any pieces are missing call **Toll Free number 1-800-782-3876** or **e-mail CISupport@Thomasville.com** for replacement parts. For faster service, have the style number handy when calling.

### Questions?

We're here to help. You may e-mail **CISupport@Thomasville.com** or call **1-800-782-3876** between **8:00a.m. - 9:00p.m., Monday - Friday** and **9:00a.m. - 5:00p.m., Saturday (Eastern Time)**. Holiday weekends will not be staffed. For faster service, have the style number handy when calling.



**WARNING...This unit is to be used for its intended purpose. Other uses may cause product to tip.**

- \* **Do not allow anyone to climb on unit.**
- \* **Put heavy items on lower drawers or shelves.**
- \* **Open one drawer at a time.**



Screws are shown actual size. Hardware may be shown smaller than actual size. Note: For reasons of manufacturing efficiencies, you may find extra hardware and unused holes in parts.



S2 1/2" Phillips-head Screw (32)  
003239

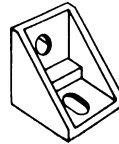

LB Plastic L-Bracket (8)  
001136



Touch-Up Pen (1)  
80113188



S3 1/2" Flat Head Screws (32)  
009686



7/8" Hardware Bolt (9)  
001092

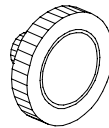

Knob (9)  
80071756

### Drawer Guides

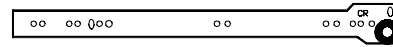

007420 (3) stamped "CR"

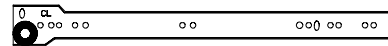

007419 (3) stamped "CL"

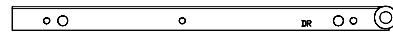

007422 (3) stamped "DR"

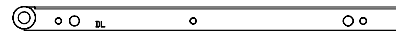

007421 (3) stamped "DL"



S4 2" Hex Head Screw (3)  
006484



Hexwrench (1)  
002673

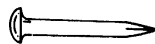

Nail (65)  
002669

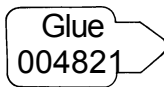

Glue  
004821



Cover-cap (10)  
80112893

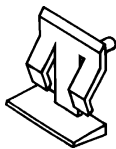

LPN Locking Shelf Pins (4)  
004053

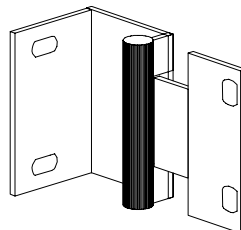

HG Hinge (2)  
80071423

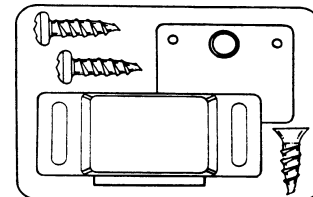

Magnetic Catch Set (1)  
MC Magnetic Catch,  
SP Strike Plate  
Screws  
008075



CS Long Cam Stud (23)  
009612



SCS Short Cam Stud (18)  
009611



CH Cam Housing (41)  
009613

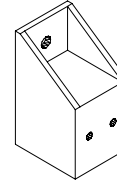

GS Guide Spacer (8)  
80052581

**Note:** All parts may not be identified with labels, but to help identify certain parts, you may see one or more types of labelling. One type is the peel-off label and the other is an ink-print on one of the unfinished edges.

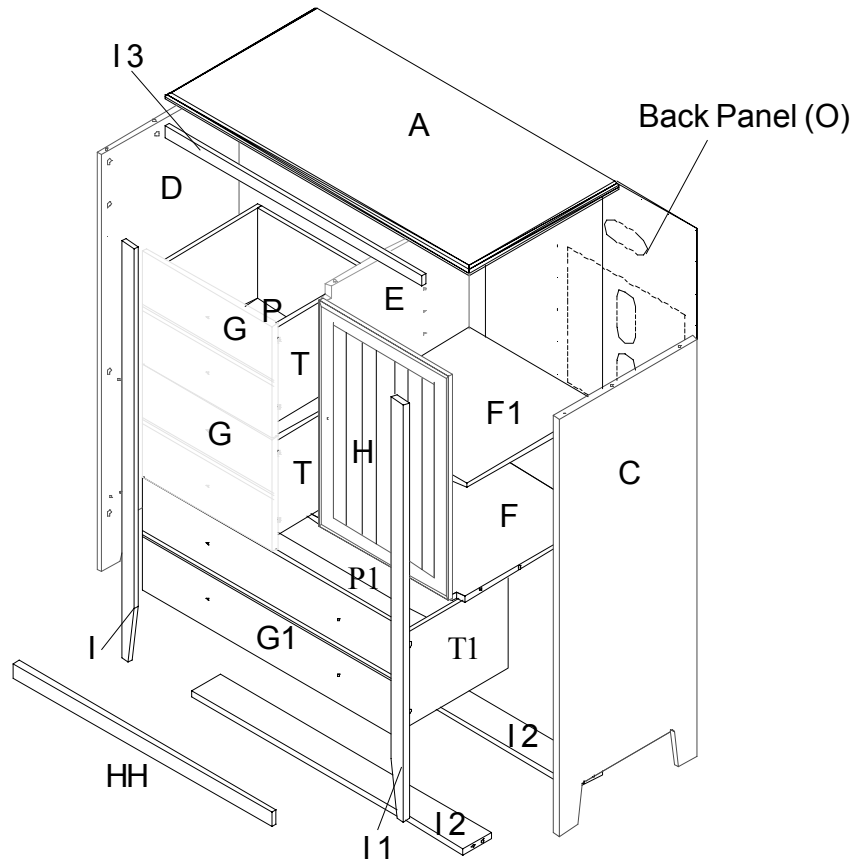

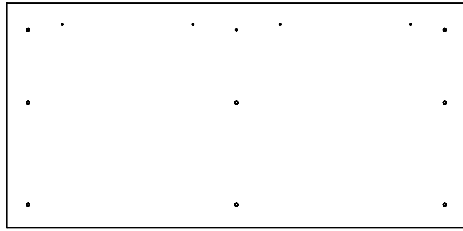

**A Top (1)**  
39-13/16" x 19-1/2"  
014015Z

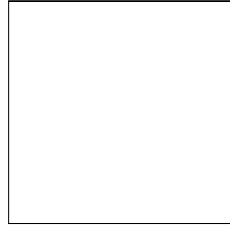

**F1 Adjustable Shelf (1)**  
17-1/4" x 17-11/16"  
061707Z



**E Partition (1)**  
26-5/16" x 18-3/4"  
052606Z

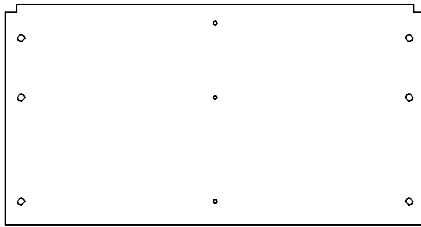

**F Mid Shelf (1)**  
35-9/16" x 18-3/4"  
063513Z

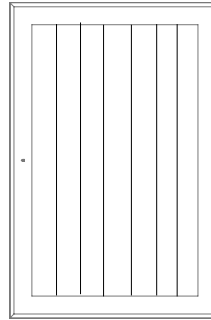

**H Door (1)**  
25-7/16" x 16-15/16"  
082506Z

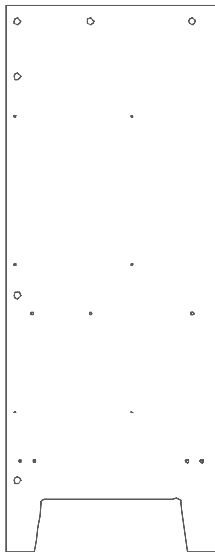

**D Left Side (1)**  
47-3/16" x 18-1/8"  
044703Z

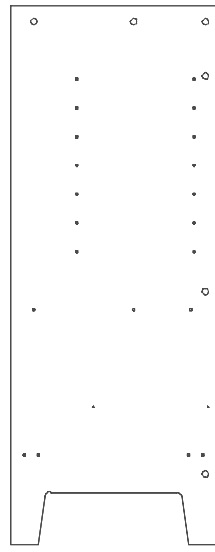

**C Right Side (1)**  
47-3/16" x 18-1/8"  
034718Z



**I3 Top Front Rail (1)**  
33-11/16" x 1-1/4"  
093437Z



**I2 Bottom Rail (2)**  
35-9/16" x 3-5/8"  
093673H



**HH Bottom Front Rail (1)**  
33-11/16" x 1-5/8"  
093438Z

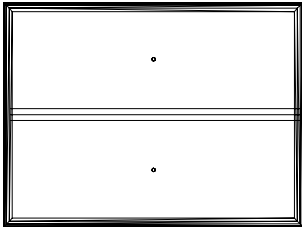

G Drawer Front (2)  
16-15/16" x 12-11/16"  
071714Z

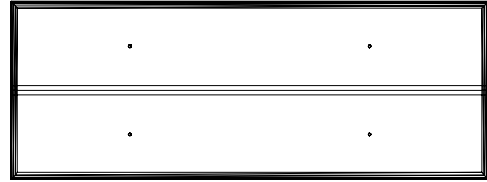

G1 Lower Drawer (1)  
34-1/16" x 12-11/16"  
073432Z

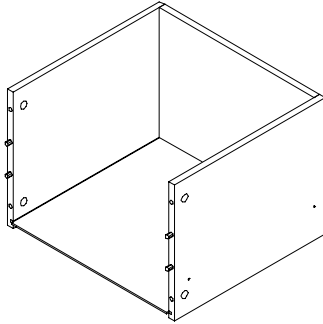

T Drawer Sides (2)  
42-13/16" x 10-11/16"  
80111827

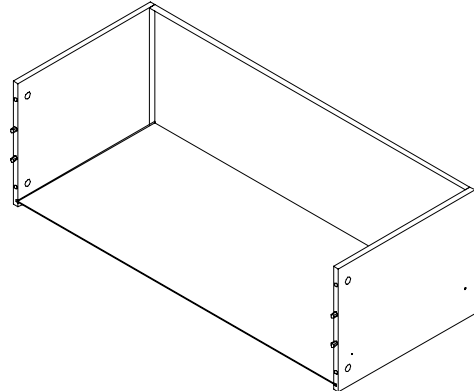

T1 Lower Drawer Sides (1)  
59-15/16" x 10-11/16"  
80111828

P Drawer Bottom (2)  
14-7/8" x 13-9/16"  
80071759

P1 Lower Drawer Bottom (1)  
32" x 13-9/16"  
80113187

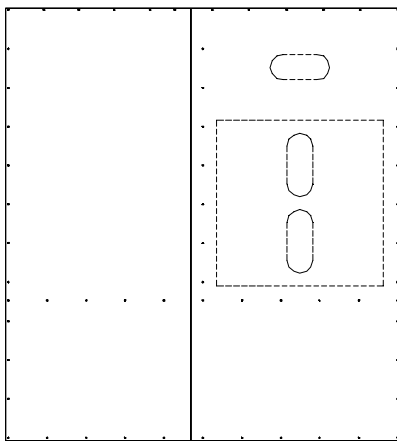

O Back Panel (1)  
40-3/16" x 36-9/16"  
80111826

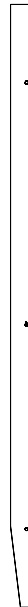

(L) Left Vertical Rail (1)  
47-1/16" x 1-5/8"  
094734Z

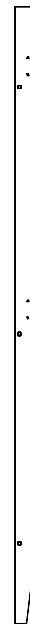

(R) Right Vertical Rail (1)  
47-1/16" x 1-5/8"  
094731Z

Follow Steps 1 - 4 to assemble Drawers (G and G1).

1

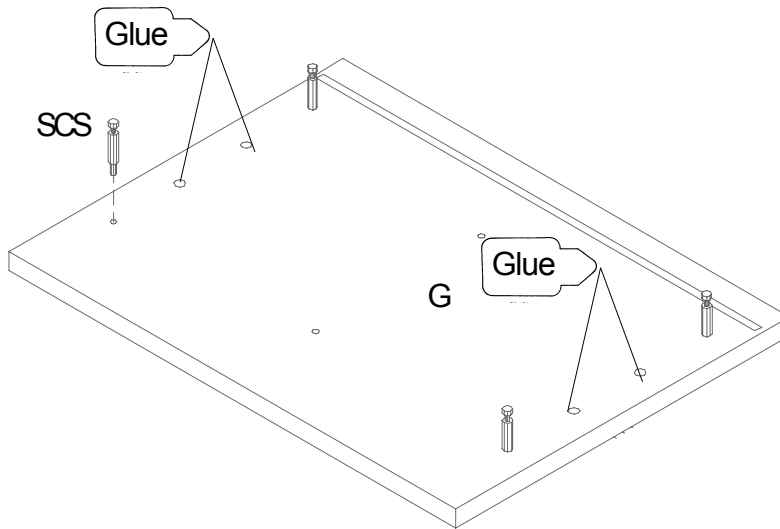
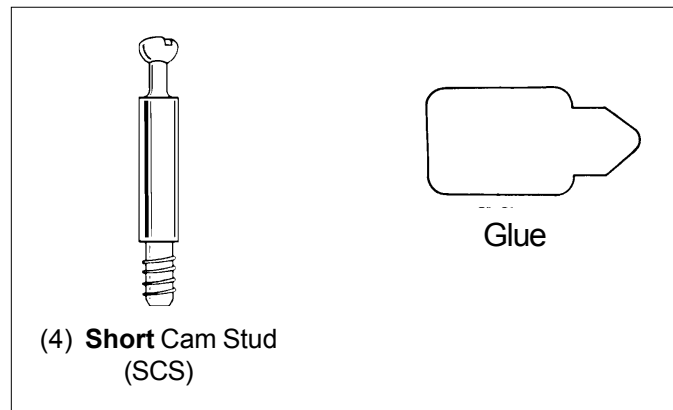

**Action Required:**

- \* Place drawer front (G) on the floor with holes facing up, as shown.
- \* Screw (4) **short** cam studs (SCS) into the appropriate holes in drawer front (G).
- \* Apply 2-3 drops of glue into (4) dowel holes in drawer front, but do not fill with glue.
- \* Spread glue evenly on the inside of the holes with a toothpick or similar object.
- \* Set aside.

# 2

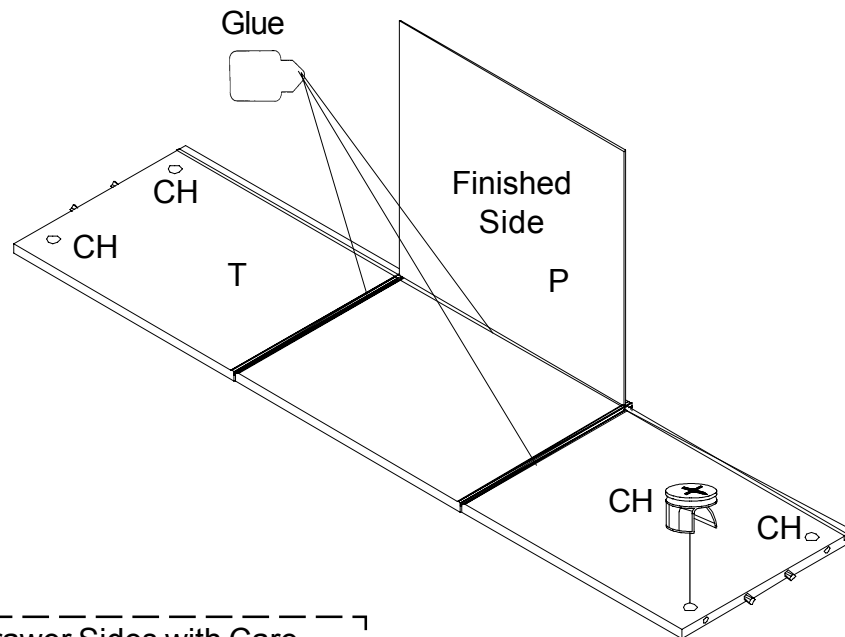
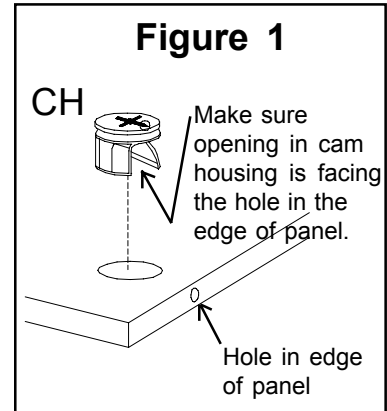
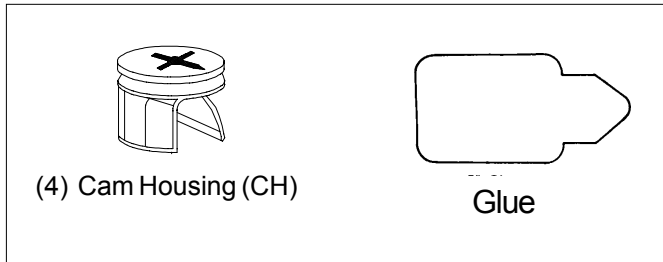

Handle Drawer Sides with Care

## Action Required:

- \* Place drawer sides (T) as shown in diagram.
- \* **SEE FIGURE 1**...Insert (4) cam housings (CH) into the holes, as shown, in drawer sides (T).
- \* Apply glue into the corner joints of drawer sides (T) and a generous amount of glue in the groove in the back of the drawer.
- \* Stand drawer bottom (P) in long groove, **finished side up**, and fold the drawer sides (T) up around the drawer bottom (P).

# 3

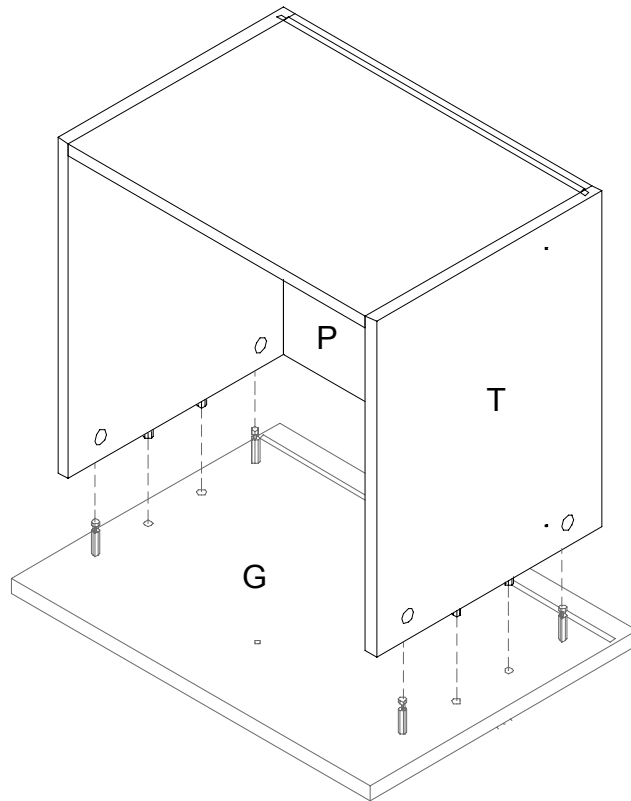
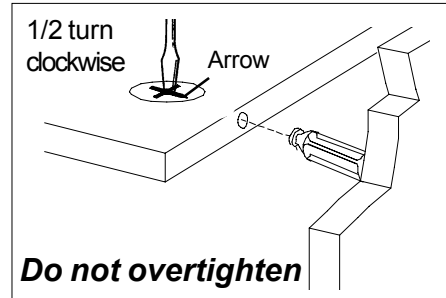
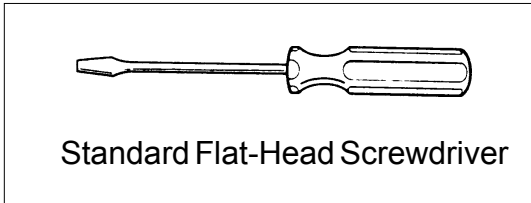

## Action Required:

- \* Place the dowels in the drawer sides (T) into the holes in drawer front (G). Note Cam studs should align with holes in drawer sides (T).
- \* Press down on the back of the drawer. If necessary, tap on drawer sides (T), using a hammer against a block of wood wrapped in a protective cloth.  
**Note: Make sure drawer bottom inserts into drawer front groove.**
- \* Wipe off excess glue with a damp cloth.
- \* Lock cam housings with a half turn clockwise of a standard flat-head screwdriver.

# 4

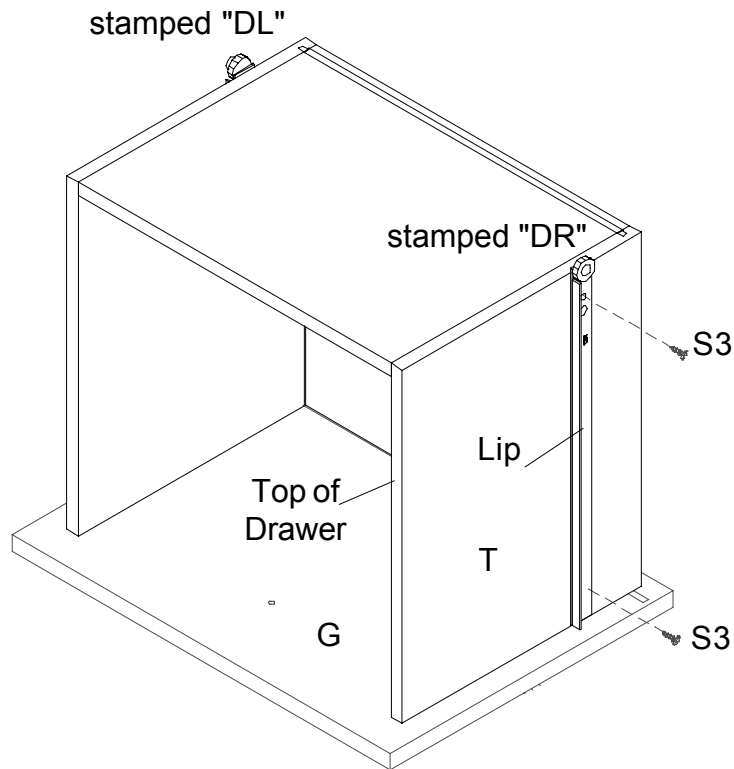
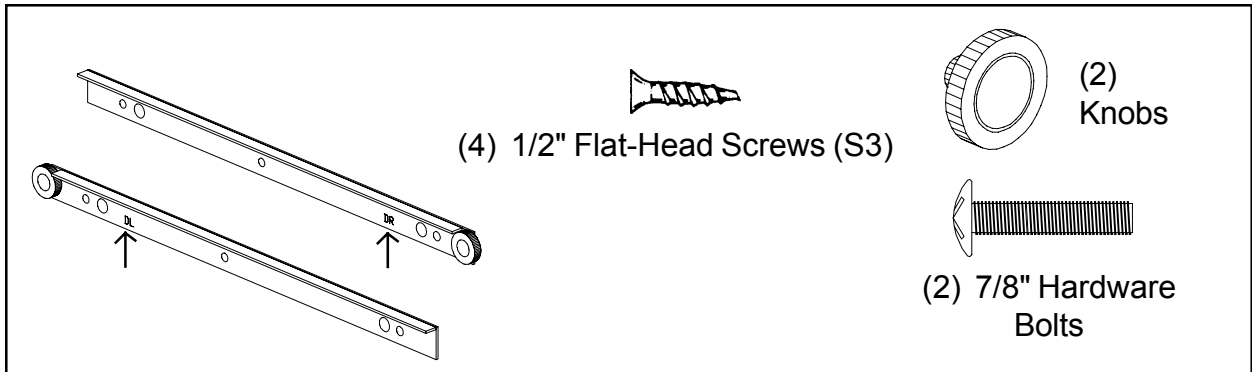

### Action Required:

**Note:** There is a right drawer guide (stamped "DR") and a left drawer guide (stamped "DL").

\* Attach drawer guides to drawer sides (T), with rollers facing toward the back, using (2) screws (S3) in each drawer guide. The drawer guides have a lip on one edge. The lip goes toward the top of the drawer, as shown.

\* Attach (2) knobs to drawer (G), using (2) 7/8" hardware bolts.

# 5

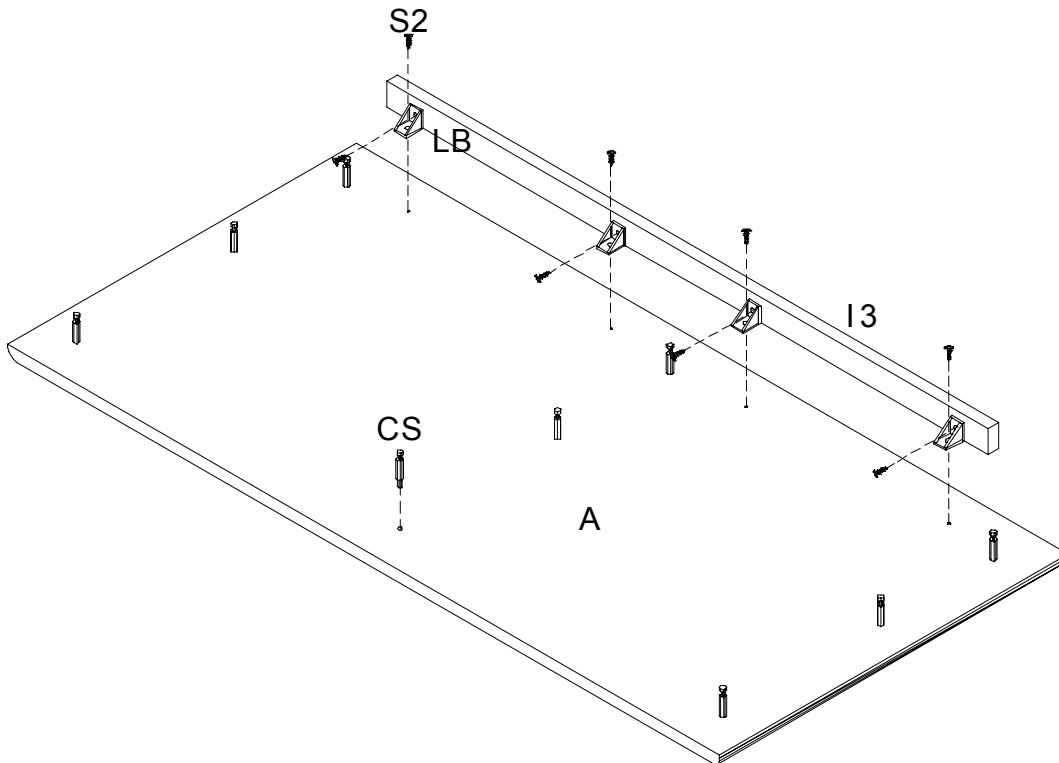
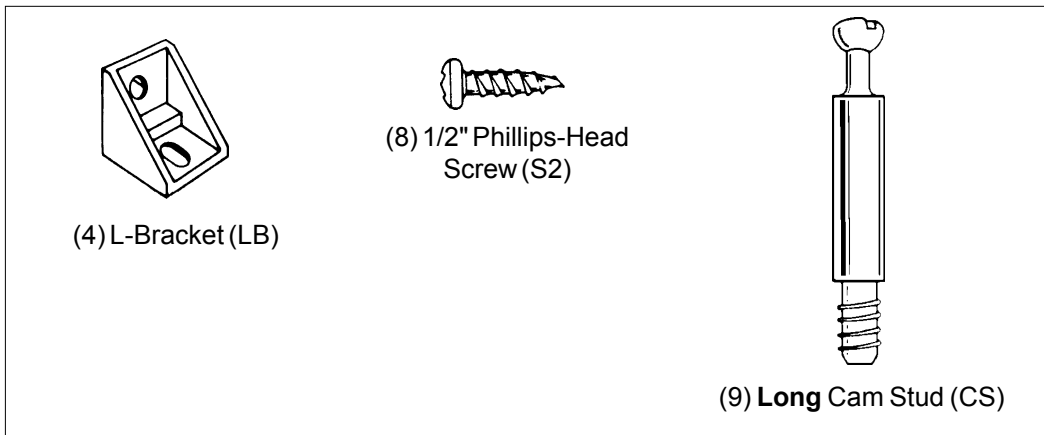

### Action Required:

- \* Align the holes in rail (I3) with the holes in top (A) for proper placement of L-brackets (LB).
- \* Attach (4) L-brackets (LB) to rail (I3), using (4) screws (S2).
- \* **Loosely**, attach rail (I3) to top (A), using (4) screws (S2).
- \* Screw (9) **long** cam studs (CS) into the holes, as shown, in top (A).

# 6

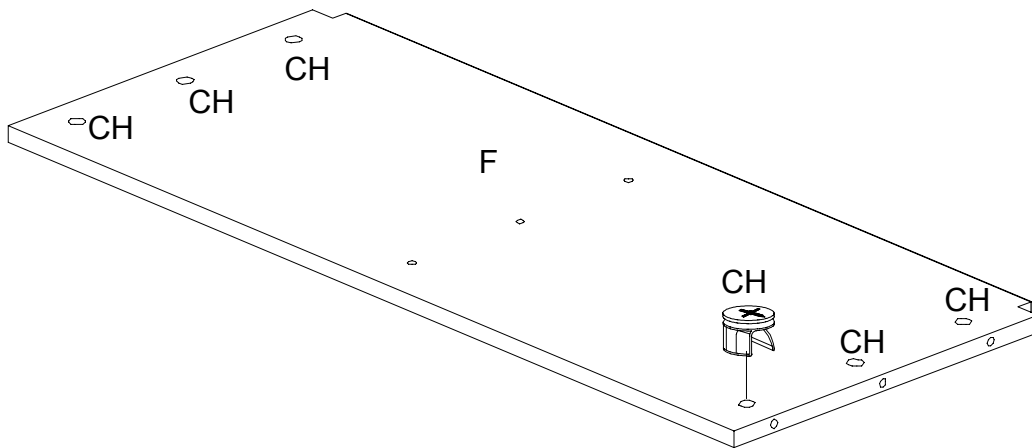
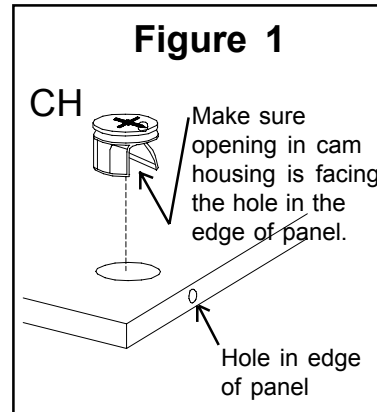
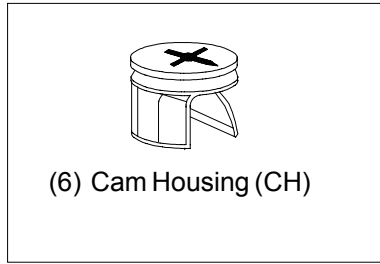

## Action Required:

- \* **SEE FIGURE 1**...Insert (6) cam housings (CH) into the holes, as shown, in mid shelf (F).  
**Press with thumb to fully seat cam housings.**

# 7

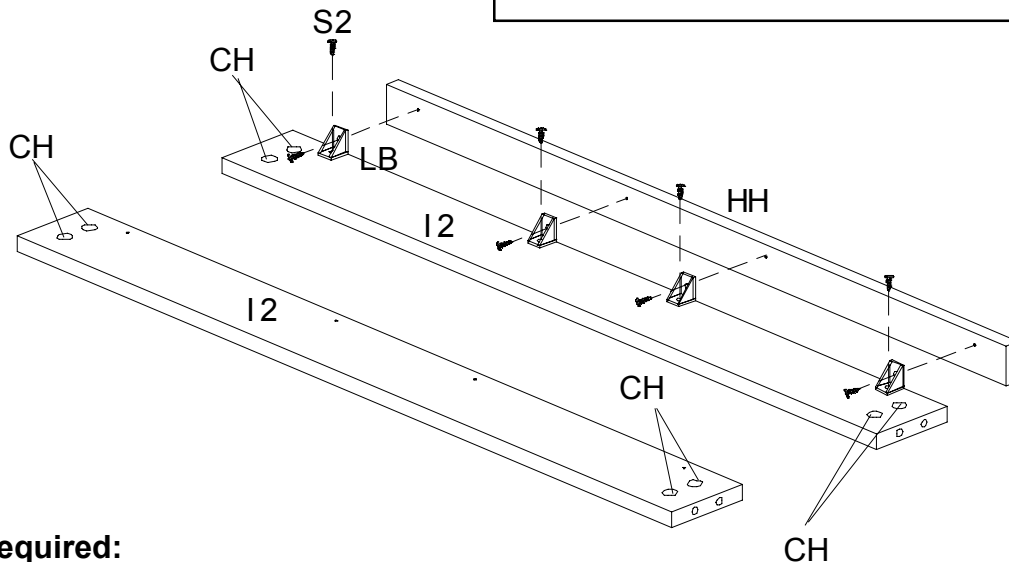
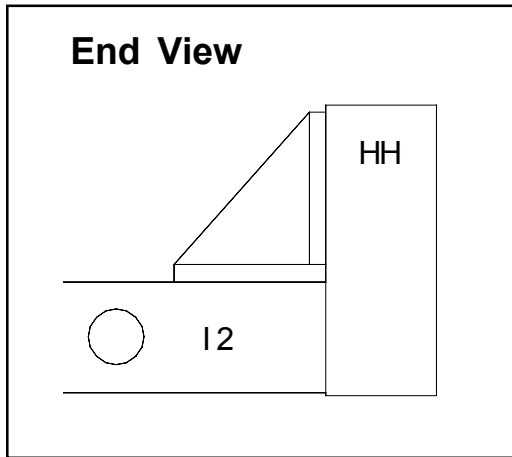
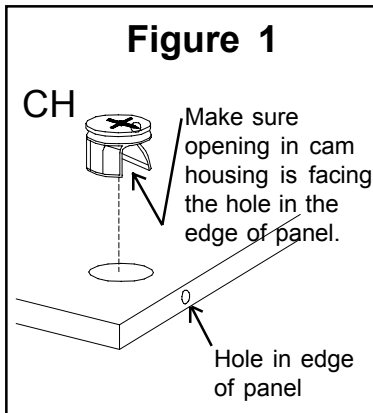
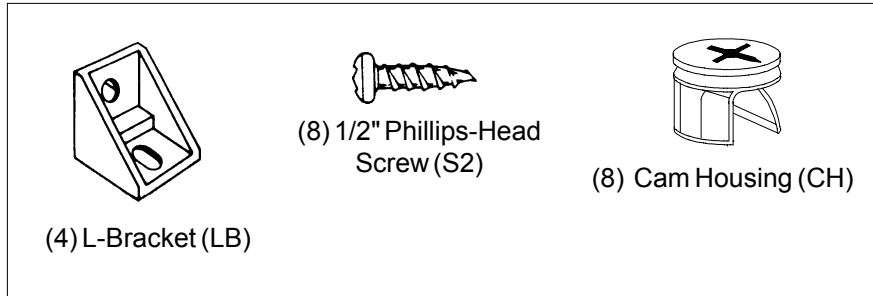

**Action Required:**

- \* **SEE FIGURE 1**...Insert (8) cam housings (CH) into the holes, as shown, in bottom rails (I 2). **Press with thumb to fully seat cam housings.**
- \* Align the holes in rail (HH) with the holes in bottom rail (I 2) for proper placement of L-brackets (LB). **Note: There is only one bottom front rail (HH) attached to bottom rail (I 2).**
- \* Attach (4) L-brackets (LB) to bottom rail (I 2), as shown, using (4) screws (S2).
- \* **Loosely**, attach rail (HH) to bottom rail (I 2), using (4) screws (S2).  
**Note: Holes are not used in the other bottom rail (I 2).**

# 8

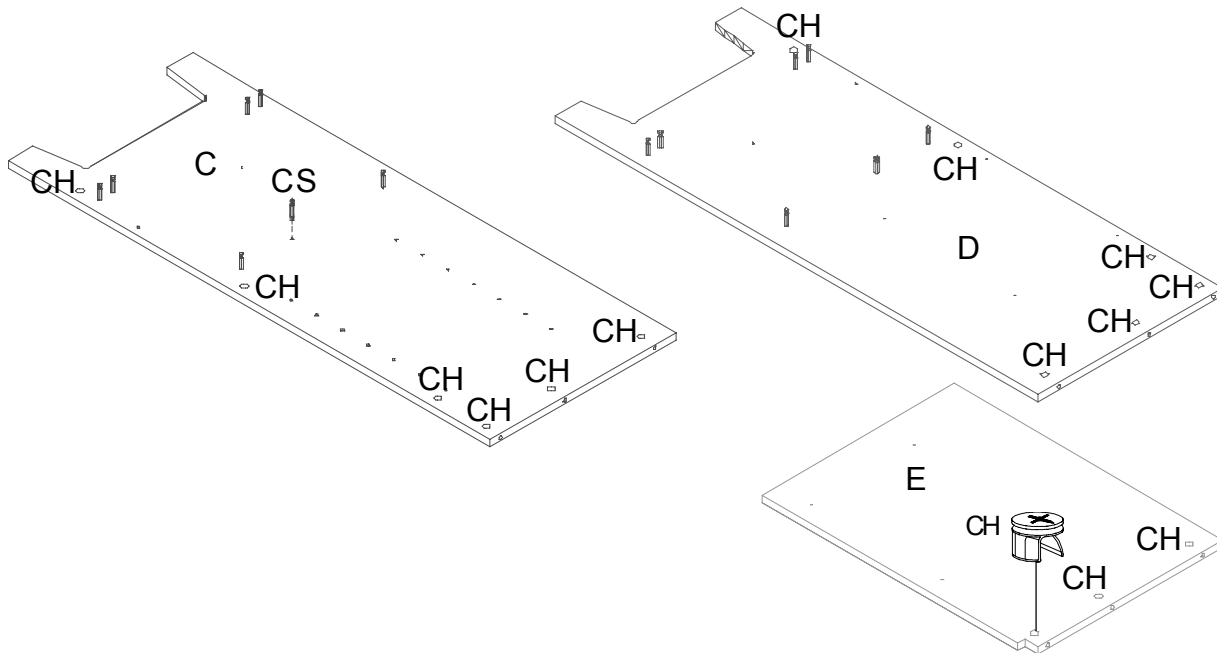
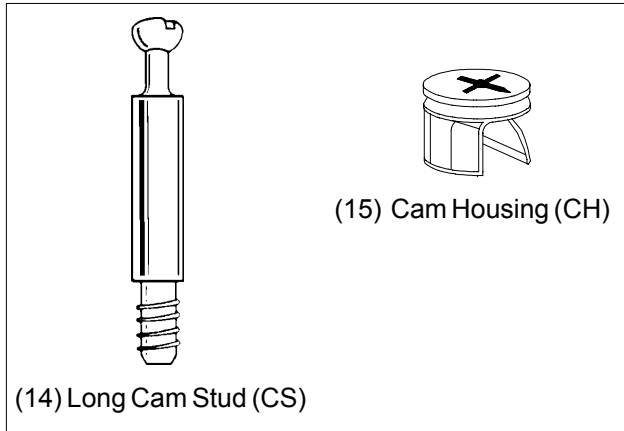

## Action Required:

- \* Screw (14) **long** cam studs (CS) into the holes, as shown, in left and right sides (D & C).  
**Press with thumb to fully seat cam housings.**
- \* Insert (15) cam housings (CH) into the holes, as shown, in left and right sides (D & C) and partition (E).

# 9

## Helpful Hint...

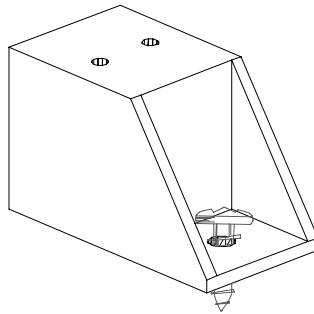

(8) Guide Spacers (GS)



(8) 1/2" Phillips-Head  
Screw (S2)

***Start screw (S2) in Guide Spacers (GS), before attaching to sides, to ensure proper alignment of the screw with predrilled holes in sides (D & C).***

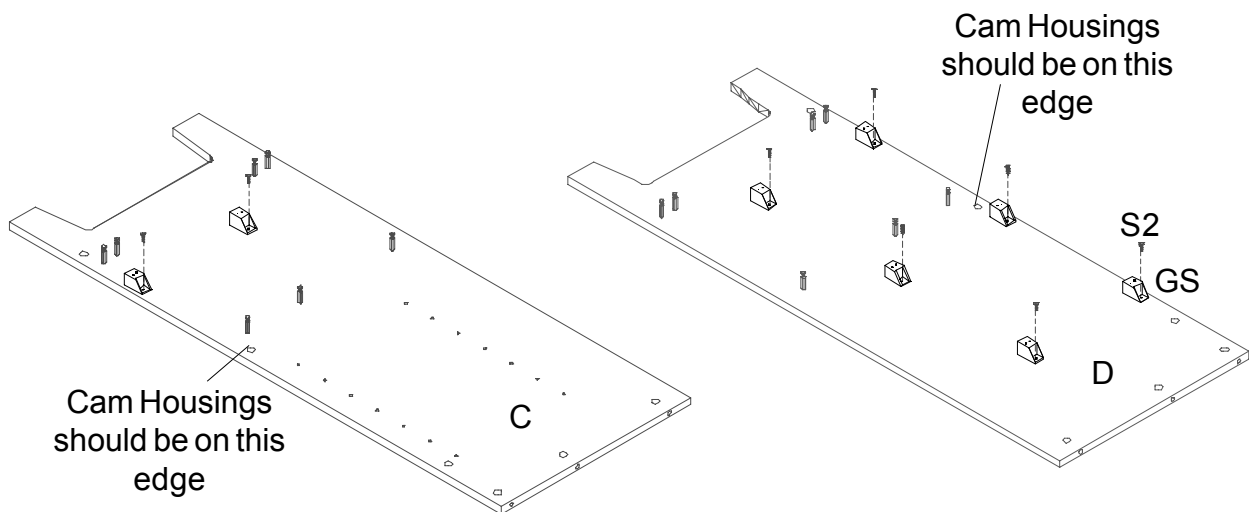

### Action Required:

\* **SEE HELPFUL HINT...** Attach (8) guide spacers (GS) to left side (D) and right side (C), as shown, using (8) screws (S2).

# 10

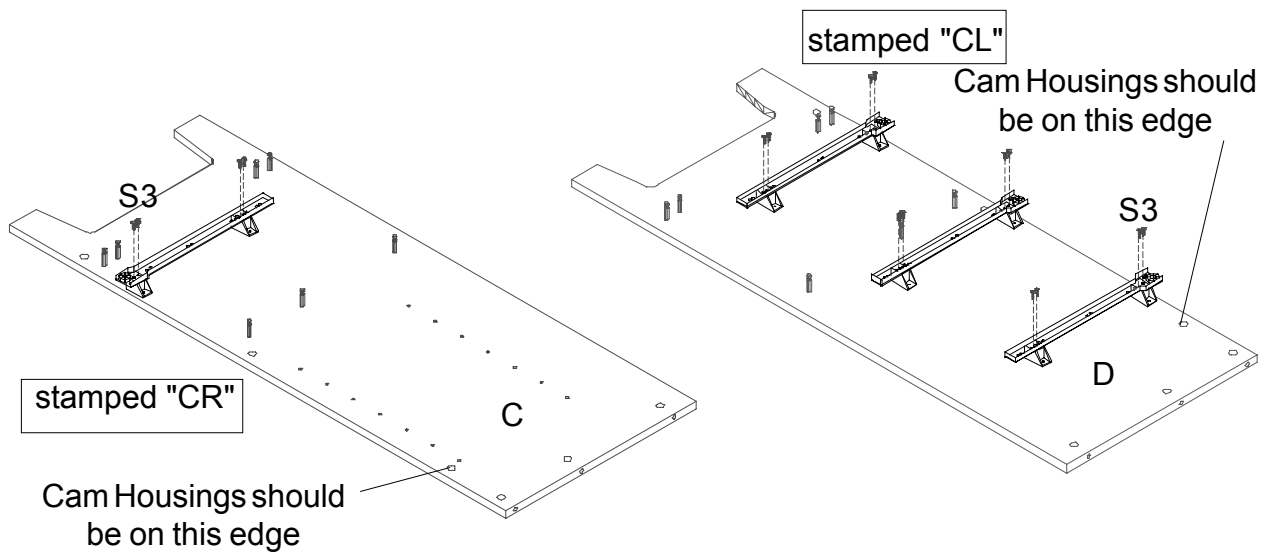
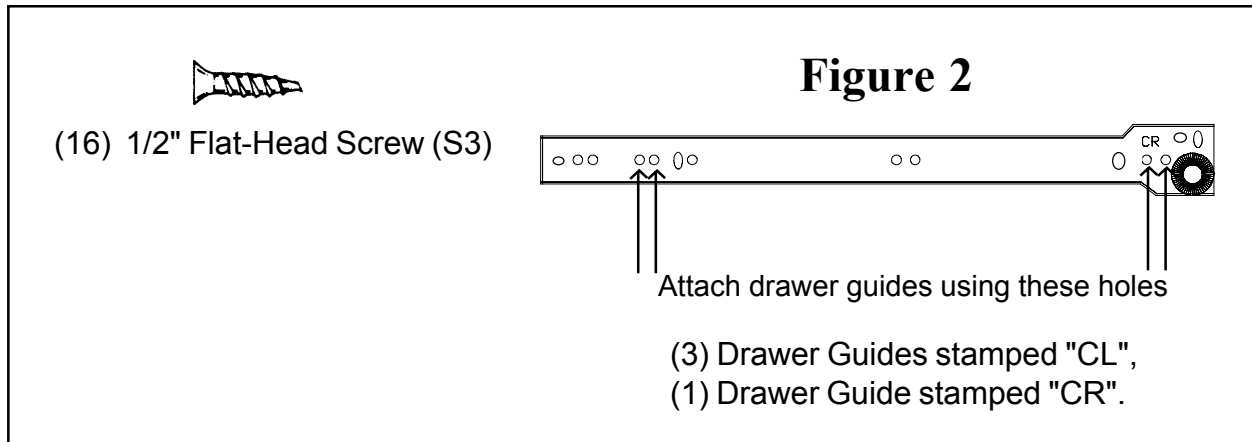

### Action Required:

Note: There is a left and a right drawer guide. The (3) guides stamped "CL" will be attached to left side (D) and the (1) guide stamped "CR" will be attached to right side (C).

\* **SEE FIGURE 2**...attach drawer guides to guide spacers (GS), using (4) screws (S3) in each guide.

# 11

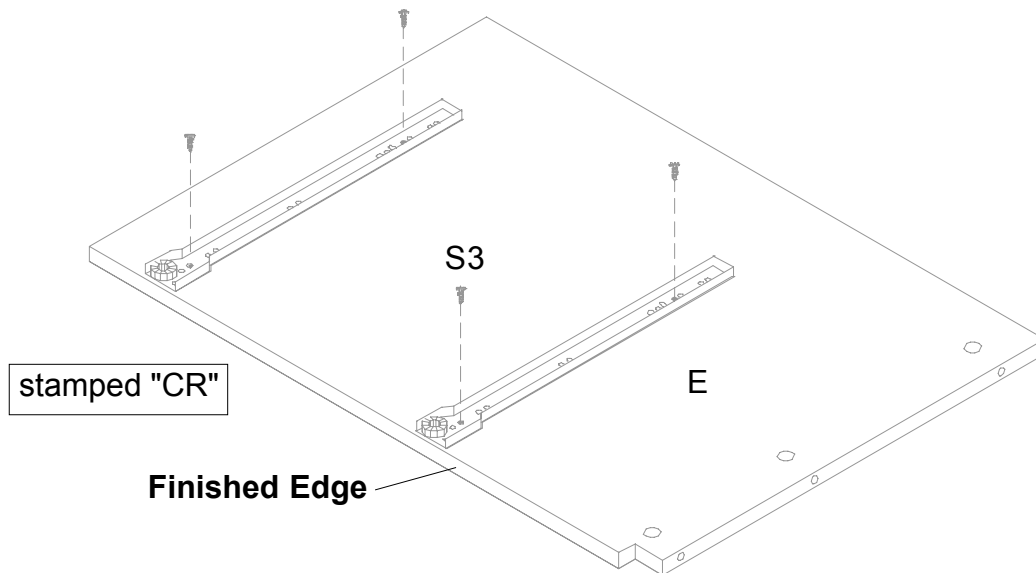
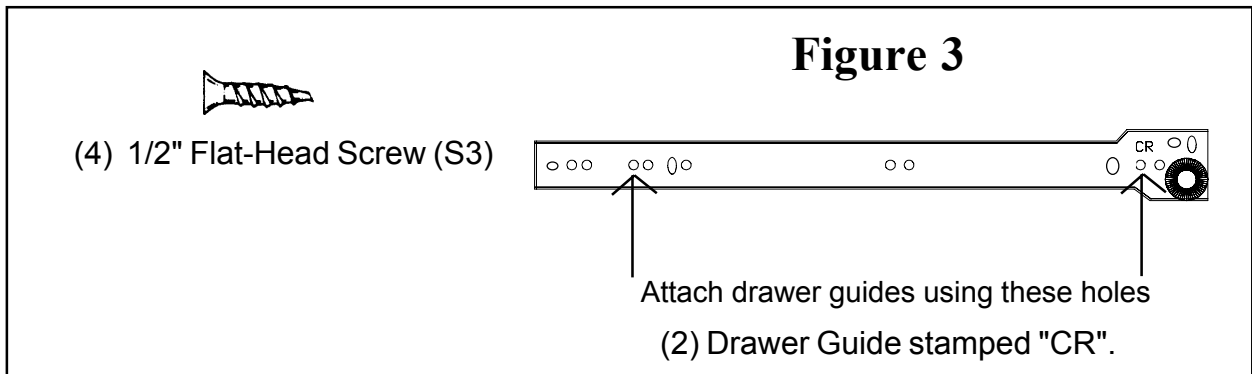

**Action Required:**

- \* **SEE FIGURE 3...**attach (2) drawer guides stamped "CR" to partition (E), using (2) screws (S3) in each guide.

# 12

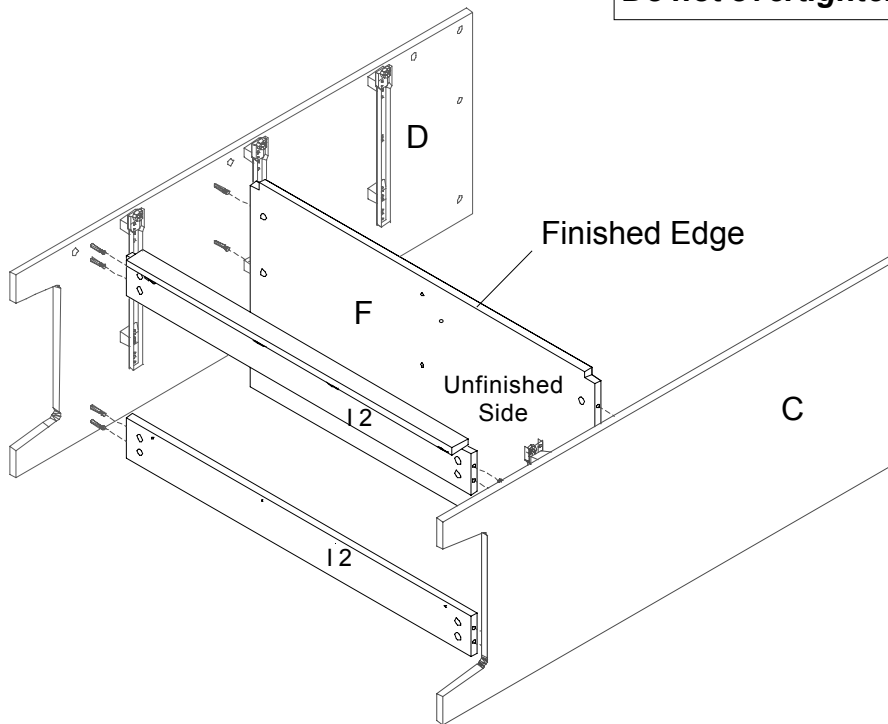
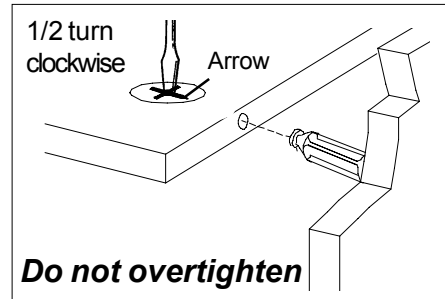
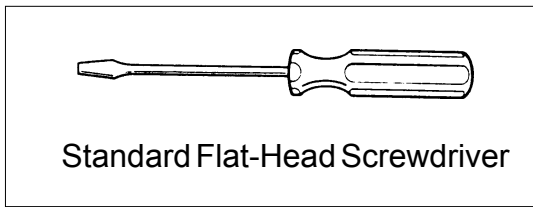

## Action Required:

- \* Place left side (D) on its back edge, as shown.
- \* **Note: Small holes in the bottom rail (I 2) should be up, as shown.** Attach bottom rails (I 2) to left side (D).
- \* Lock cam housings with a half turn clockwise of a standard flat-head screwdriver. DO NOT OVER-TIGHTEN.
- \* Attach shelf (F) to left side (D), as shown.
- \* Lock cam housings. DO NOT OVER-TIGHTEN.
- \* Attach right side (C) to shelf (F) and bottom rails (I 2).
- \* Lock cam housings. DO NOT OVER-TIGHTEN.

# 13

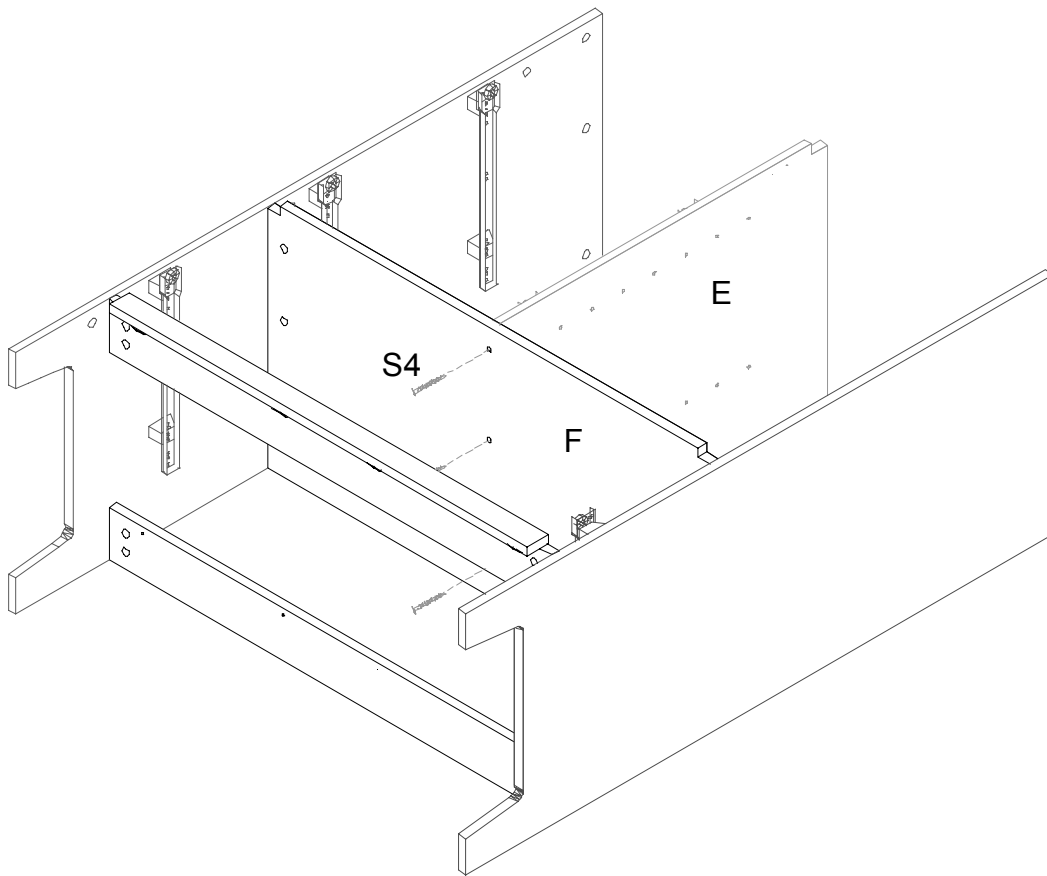
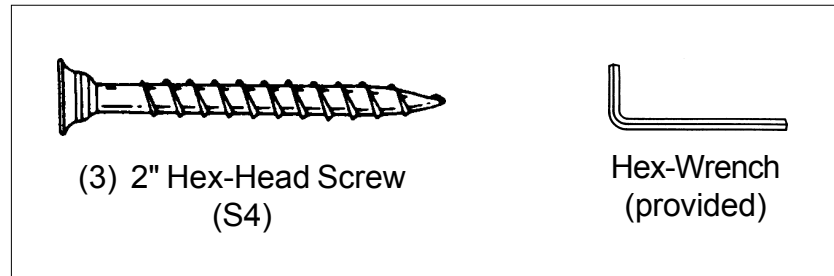

**Action Required:**

\* Attach partition (E) to mid shelf (F), using (3) screws (S4).

# 14

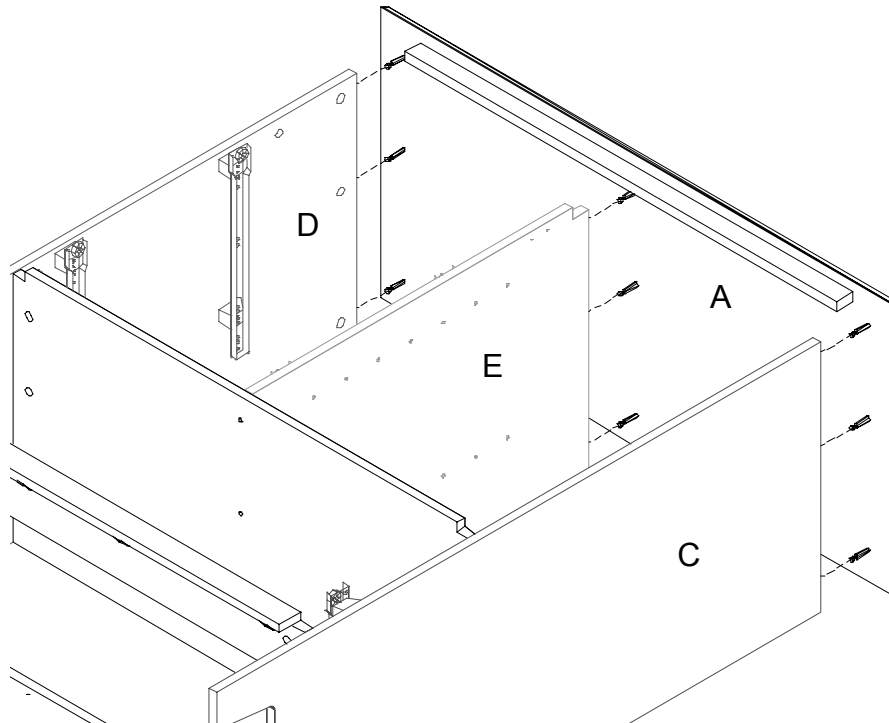
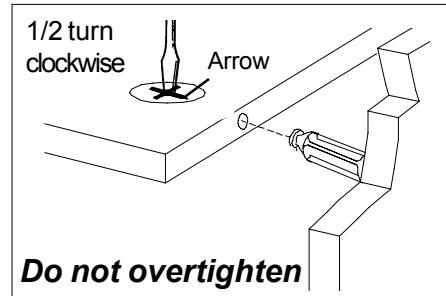
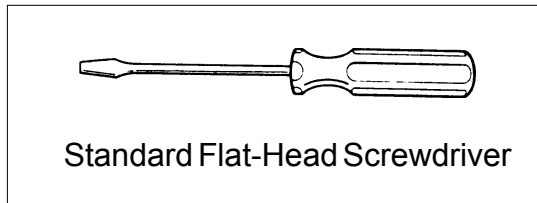

## Action Required:

- \* Place top (A) to left and right sides (D & C) and partition (E).
- \* Lock cam housings with a half turn clockwise using a standard screwdriver.  
DO NOT OVER-TIGHTEN.

# 15

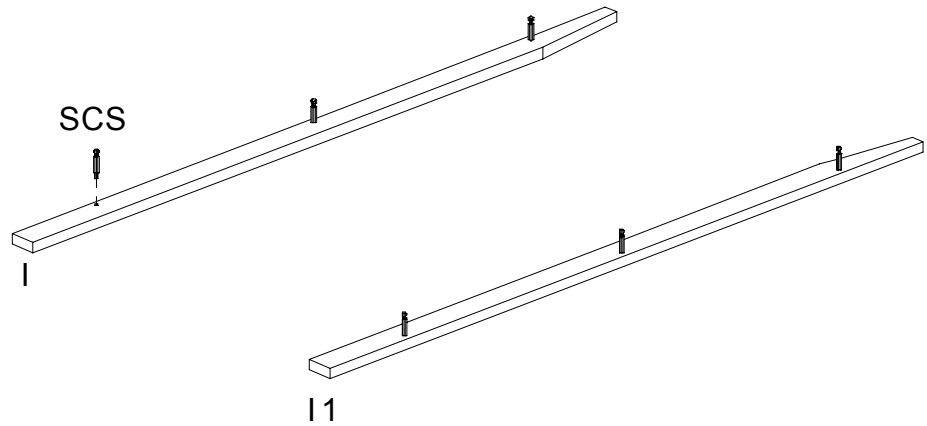
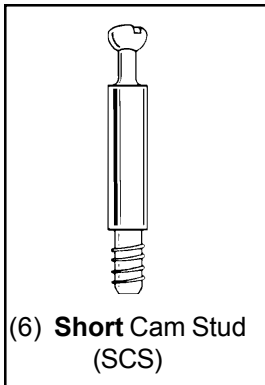

### Action Required:

- \* Screw (6) **short cam studs (SCS)** into each of the holes, as shown, in left and right vertical rails (I & I1).

# 16

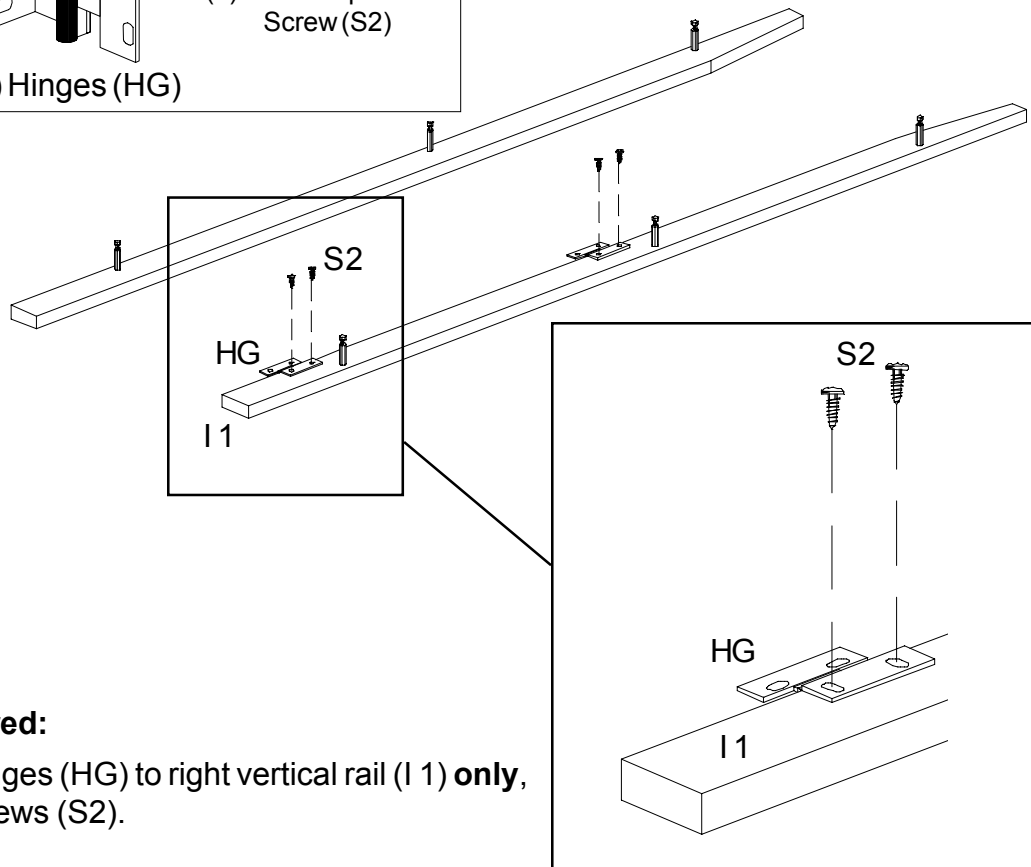
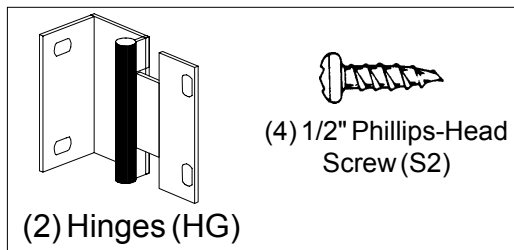

### Action Required:

- \* Attach (2) hinges (HG) to right vertical rail (I 1) **only**, using (4) screws (S2).

# 17

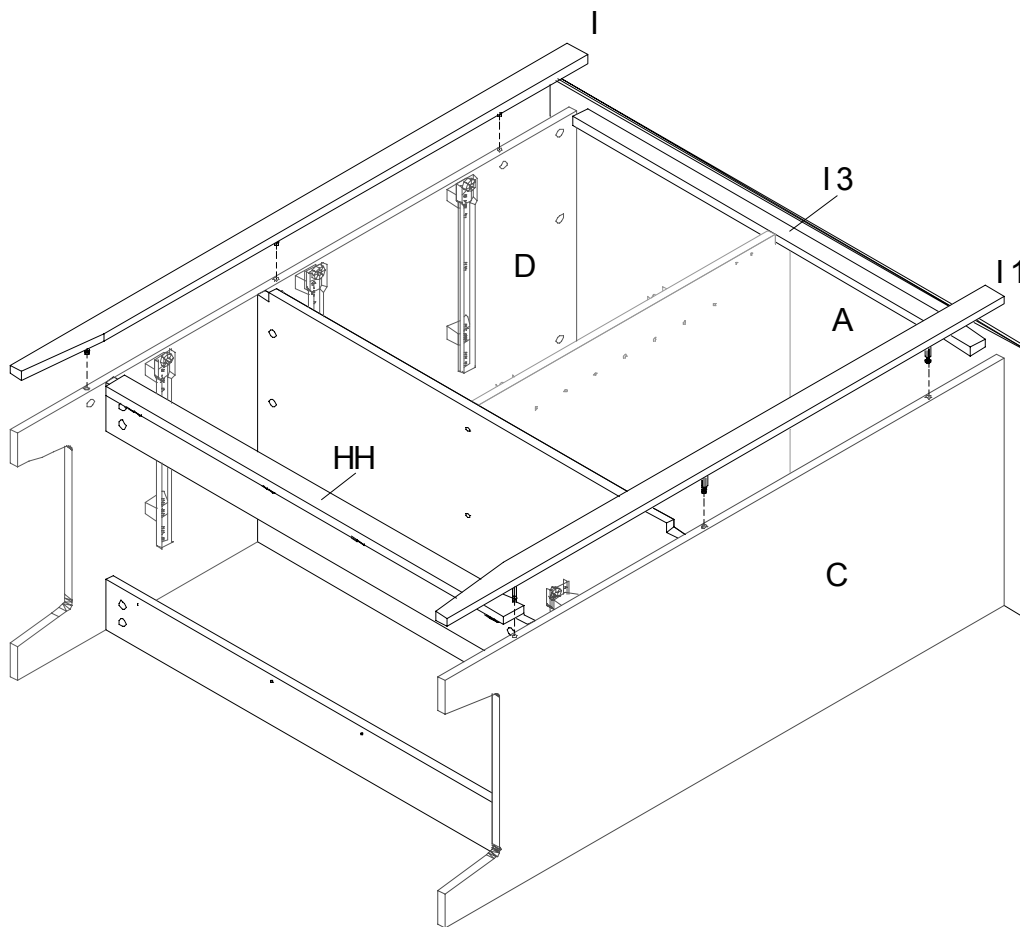
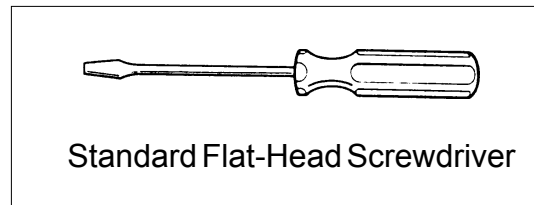

### Action Required:

- \* Place left vertical rail ( I ) to left side (D).
- \* Place right vertical rail ( I 1 ) to right side (C).
- \* Lock cam housings.
- \* Tighten screws in L-Brackets in top front rail (I 3) and bottom front rail (HH).

# 18

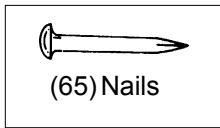

Note: Back panel adds stability to case.

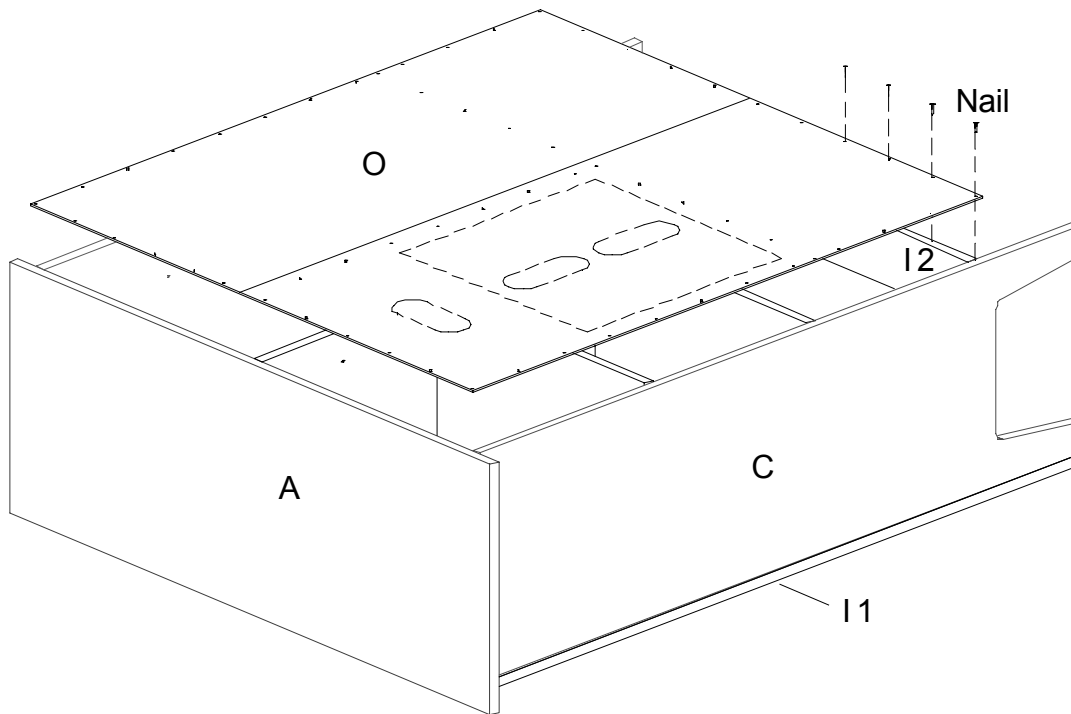

## Action Required:

- \* **Fold hinges in vertical rail (I1) to prevent bending before placing case on its front.**
- \* With a helper, carefully turn unit over with the front against the floor.
- \* Position back panel (O) even with the bottom edge of bottom rail (I2).
- \* Make sure panel (O) fits square and even side to side. **If it doesn't, adjust unit into square by pushing or pulling on one corner of the unit until back panel fits squarely.**
- \* While nailing into pilot holes, take care to hammer nails in straight.

# 19

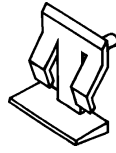

(4) Locking Shelf Pin (LPN)

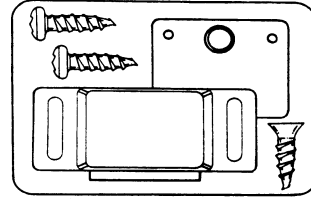

(1) Magnetic Catch Set  
MC Magnetic Catch

**Note: Strike Plate with flat-head screw will be put on in a later step.**

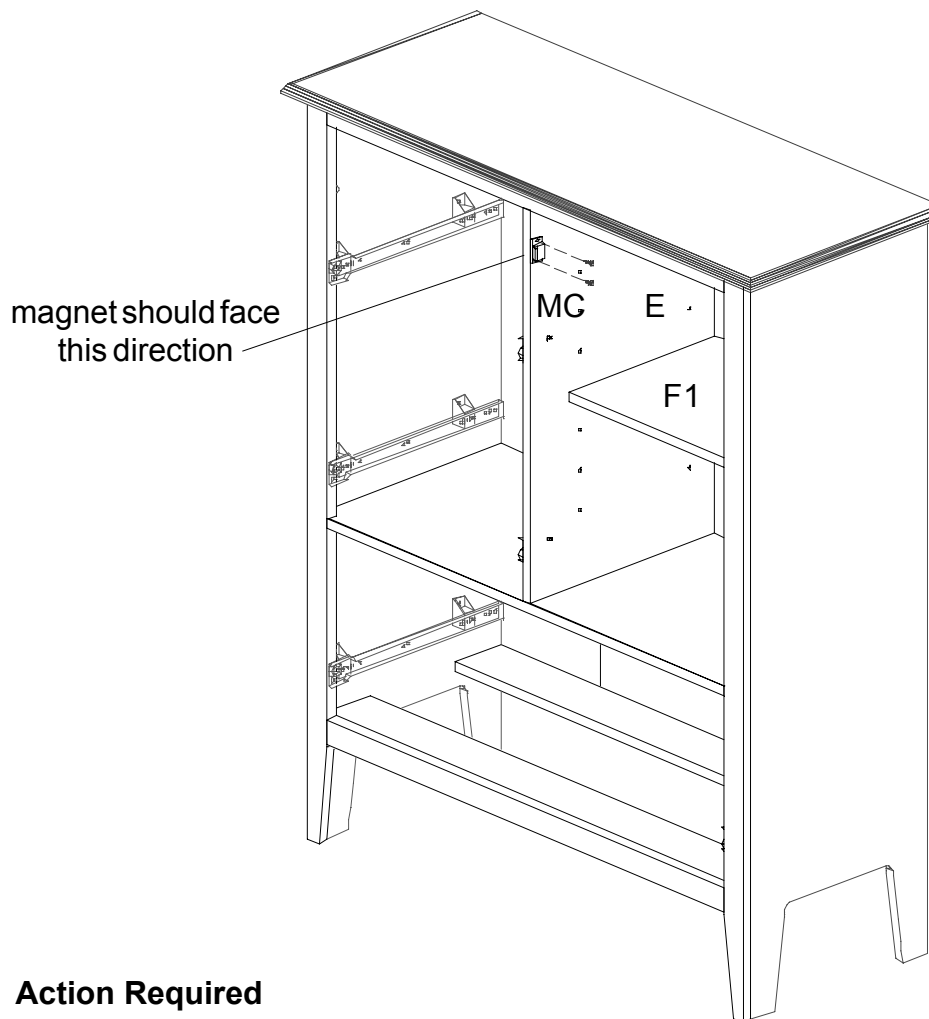

**Helpful Hint**  
Slide magnetic catch (MC) as far as you can toward the front edge of partition (E) before tightening.

## Action Required

- \* To install adjustable shelf (F1), push (4) locking shelf pins (LPN) into the holes at the height you desire.
- \* Position the shelf so that it rests on top of the locking shelf pins and push down to lock in place.
- \* **SEE HELPFUL HINT**...Attach magnetic catch (MC) to partition (E), using the round-head screws provided in the small plastic bag.

# 20

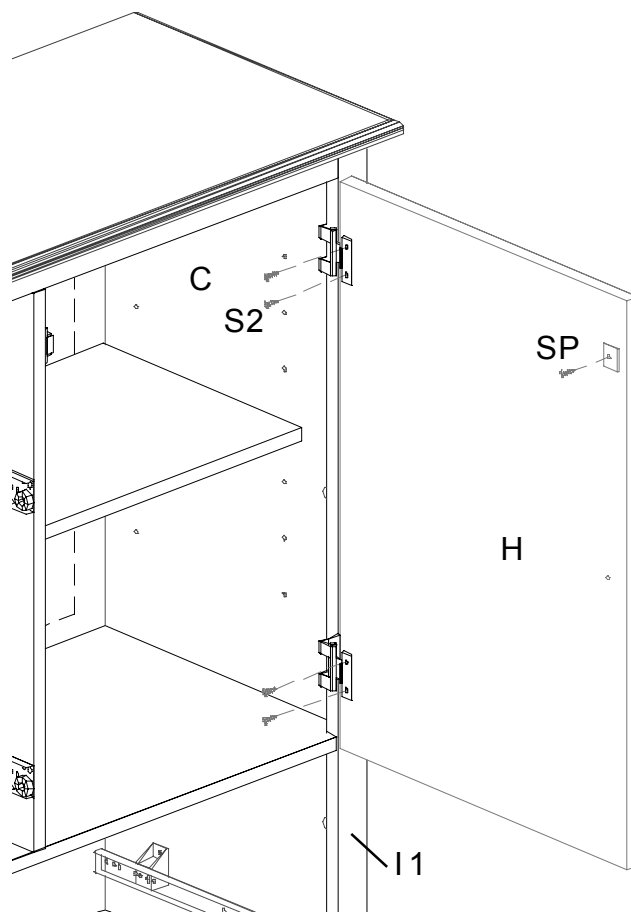
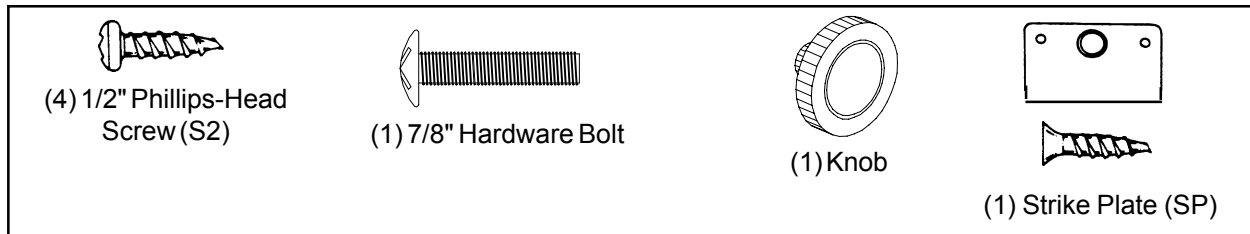

## Action Required:

- \* Attach door (H) to right vertical rail (I1), using (4) screws (S2).
- \* **Adjustment may be made to door (H) by loosening screws in hinges, adjusting and retightening.**
- \* Attach strike plate (SP) to door (H), using the flat-head screw provided in the small plastic bag.
- \* Attach knob to door (H), using 7/8" hardware bolt.

Note: Make sure all cam housings are in the locked position.

## 21

Install the drawers.

Make sure glue in drawers are completely dry before placing items in drawers.

## 22

\* Decorative cover caps are provided to cover exposed cam housings.

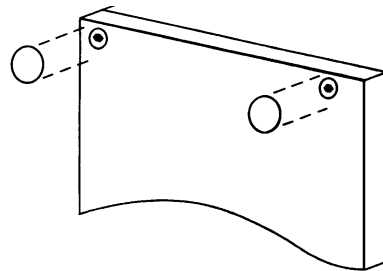

# 23

**THIS UNIT HAS BEEN DESIGNED FOR THE WEIGHTS SHOWN. EXCEEDING THESE RECOMMENDED WEIGHTS COULD RESULT IN EXCESSIVE "SAGGING" OF THE SHELF. EXTREME OVERLOADING COULD CAUSE FAILURE OF THE SHELF AND POSSIBLE INJURY.**

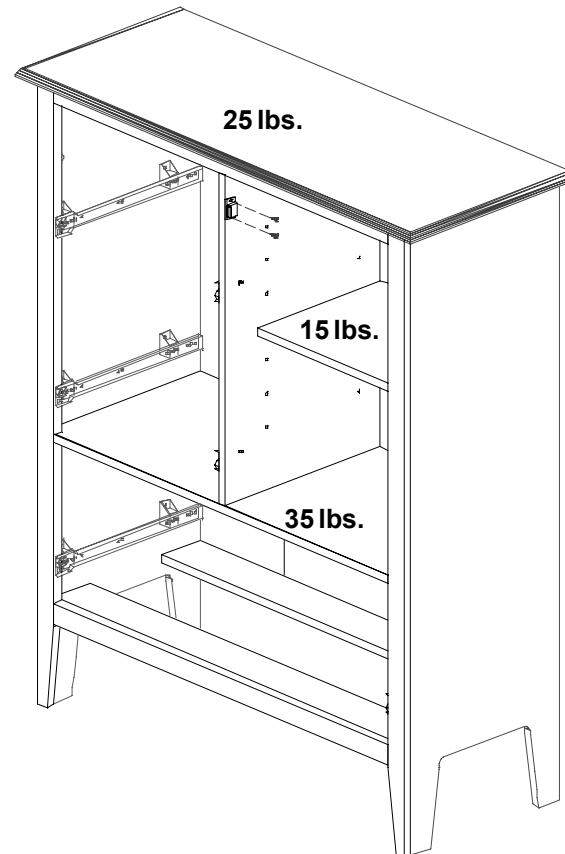

**This unit has been designed for no larger than 15" diagonal TV and the maximum weight of 35 lbs. Exceeding this recommended weight could result in excessive "sagging" of the shelf. Extreme overloading could cause failure of the shelf and possible injury.**



A touch-up pen has been provided for any touch up needed.

That's it! You've finished assembling your Armoire



## **Furniture Care Instructions:**

**Dust with a clean, lint-free cloth. Use a spray furniture polish as needed. Small nicks and scratches can be touched up with a furniture touch-up stick.**

MRP- 80113325  
1104