

Country Lane Five Drawer Chest

Style # 563-320 (Pine) DPCI# 074-09-0701

Assembly Instructions (Carysbrook)

CONGRATULATIONS

You've purchased a fine furniture product by



All of our easy-to-assembly furniture is solidly built and rigorously tested to ensure years of enjoyment.

We're here to help. Just call **1-800-782-3876** or e-mail **CISupport@Thomasville.com**

BEFORE YOU BEGIN

You may find it helpful to have a helper while assembling unit.



We've included easy to follow step-by-step instructions which have been carefully written to ensure quick, easy assembly of your furniture. Be sure to read the instructions (a time saver in the long run).

Identify all parts and hardware. If any pieces are missing call **Toll Free number 1-800-782-3876** or e-mail **CISupport@Thomasville.com** for replacement parts. For faster service, have the style number handy when calling.

Questions?

We're here to help. You may e-mail **CISupport@Thomasville.com** or call **1-800-782-3876** between **8:00a.m. - 9:00p.m., Monday - Friday** and **9:00a.m. - 5:00p.m., Saturday (Eastern Time)**. Holiday weekends will not be staffed. For faster service, have the style number handy when calling.



WARNING...This unit is to be used for storage only. Other uses may cause product to tip.

- * **Do not allow anyone to climb on unit.**
- * **Put heavy items on lower drawers.**
- * **Open one drawer at a time.**

Tools

You will need a standard flat-head screwdriver, Phillips head screwdriver and a hammer.

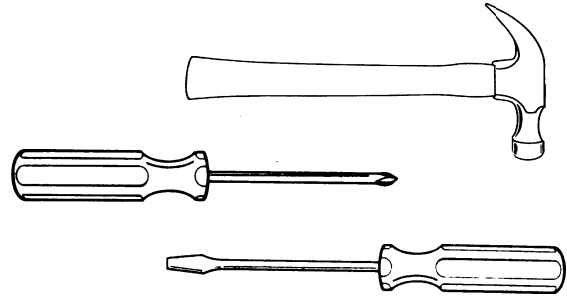

Parts List

Screws are shown actual size. Hardware may be shown smaller than actual size.

Before you begin assembly, lay all pieces out on the floor according to these illustrations.

Note: For reasons of manufacturing efficiencies, you may find extra hardware and unused holes in parts.



S2 1/2" Phillips-head Screw (32)
002262



S3 1/2" Flat Head Screws (60)
009686



7/8" Hardware Bolt (7)
001092

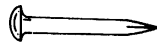

Nail (46)
002669



Cover-cap (5)
80112983

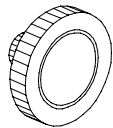

Knob (7)
80071756



CS Long Cam Stud (18)
009612

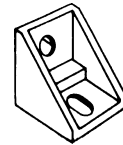

LB Plastic L-Bracket (6)
001136



CH Cam Housing (34)
009613



SCS Short Cam Stud (16)
009611

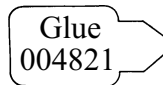

Glue
004821



Touch-Up Pen (1)
80113188

Note: All parts may not be identified with labels, but to help identify certain parts, you may see one or more types of labelling. One type is the peel-off label and the other is an ink-print on one of the unfinished edges.

Drawer Guides

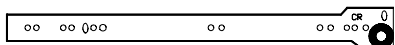

007420 (5) stamped "CR"

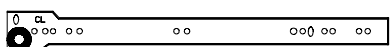

007419 (5) stamped "CL"



007422 (5) stamped "DR"

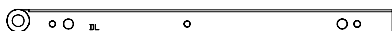

007421 (5) stamped "DL"

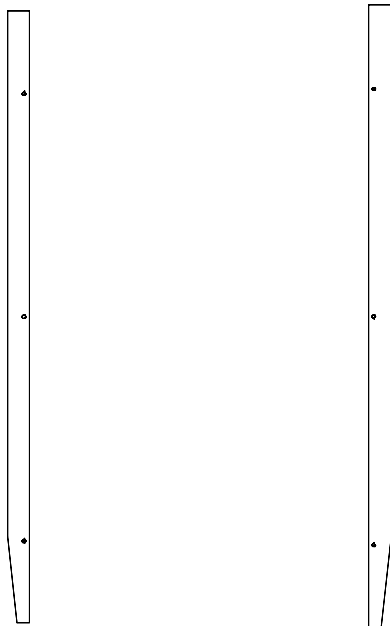
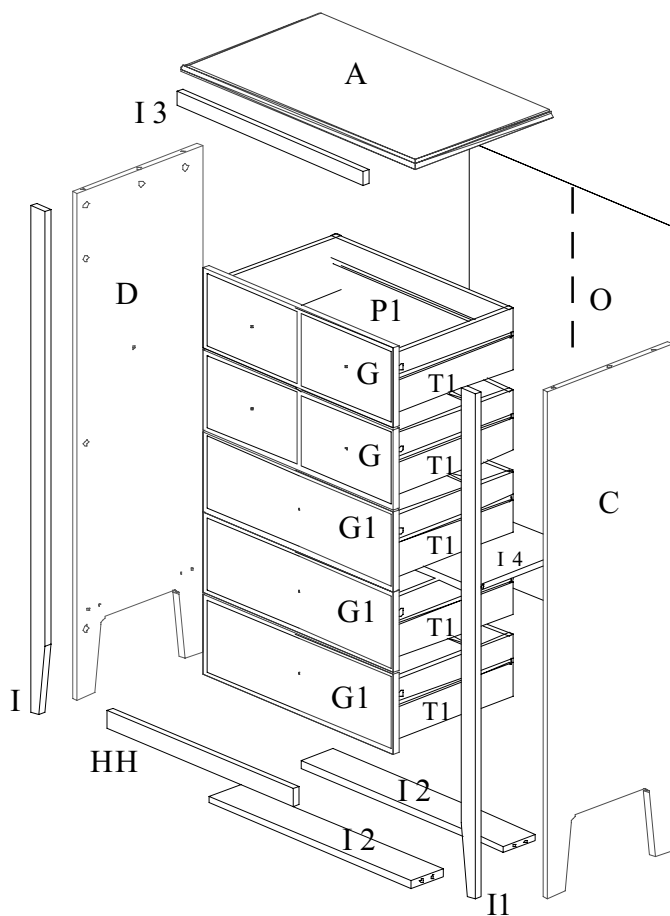

(I) Left Vertical Rail (1) 45-3/8" x 1-5/8" 094569Z
 (I1) Right Vertical Rail (1) 45-3/8" x 1-5/8" 094568Z

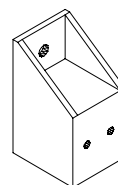

GS Guide Spacer (20) 80052581

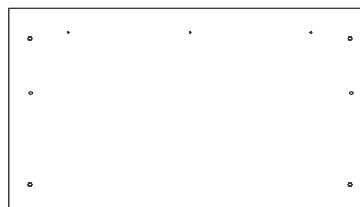

A Top (1) 28-1/8" x 19-1/2" 012803Z

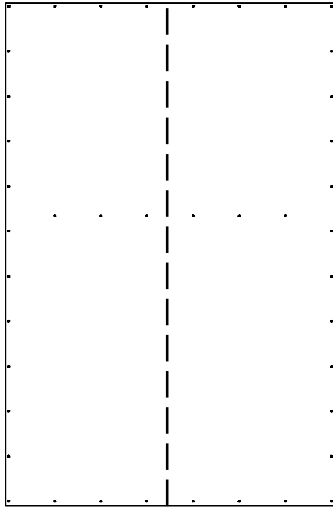

O Back Panel (1)
38-1/2" x 25-3/16"
80112768

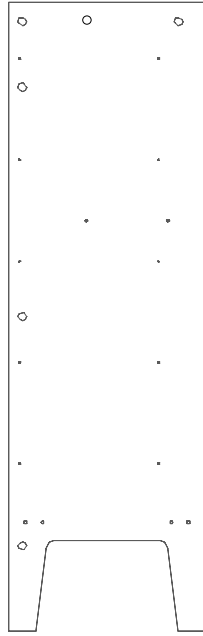

D Left Side (1)
45-1/2" x 18-1/8"
044552Z

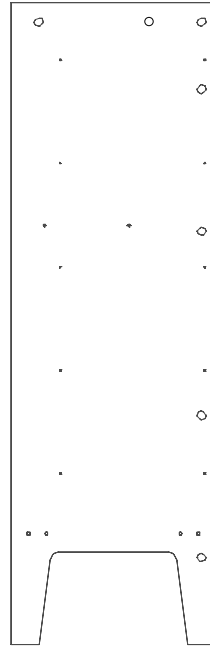

C Right Side (1)
45-1/2" x 18-1/8"
034552Z

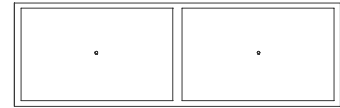

G Top Drawer (2)
22-3/4" x 7-3/16"
072309Z



G1 Lower Drawer (3)
22-3/4" x 7-3/16"
072310Z

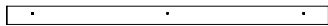

I 3 Top Front Rail (1)
22-5/16" x 1-1/4"
092215Z



I 4 Support Shelf (1)
24-3/16" x 11-3/4"
412427H

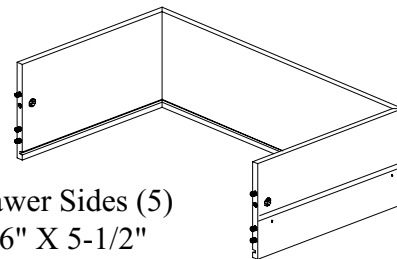

T1 Drawer Sides (5)
48-9/16" X 5-1/2"
204813T

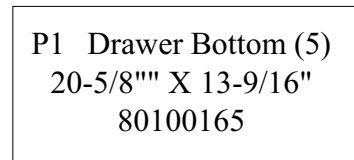

P1 Drawer Bottom (5)
20-5/8" X 13-9/16"
80100165

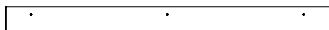

HH Bottom Front Rail (1)
22-5/16" x 1-5/8"
092216Z



I 2 Bottom Rail (2)
24-3/16" x 3-5/8"
092421H

1

Parts needed for this step:

Drawer Front (G1).

Hardware needed for this step:

(2) **Short** Cam Studs (SCS), Glue.

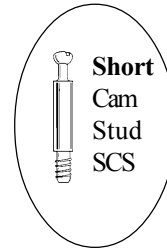

Action Required:

- * Place drawer front (G1) on the floor with holes facing up, as shown.
- * Screw (2) **short** cam studs (SCS) into the appropriate holes in drawer front (G1).
- * Apply 2-3 drops of glue into each dowel hole in drawer front, but do not fill with glue.
- * Spread glue evenly on the inside of the holes with a toothpick or similar object.
- * Set aside.

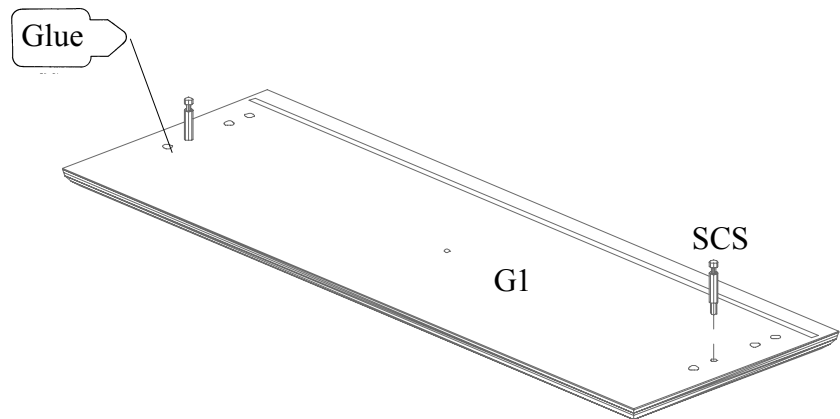

2

Parts needed for this step:

Drawer Sides (T1), Drawer Bottom (P1).

Hardware needed for this step:

(2) Cam Housings (CH), Glue.

Action Required:

- * Place drawer sides (T1) as shown in diagram.
- * **SEE FIGURE 1**...Insert (2) cam housings (CH) into the holes, as shown, in drawer sides (T1).
- * Apply glue into the corner joints of drawer sides (T1).
- * Stand drawer bottom (P1) in long groove, **finished side up**, and fold the drawer sides (T1) around the drawer bottom (P1).

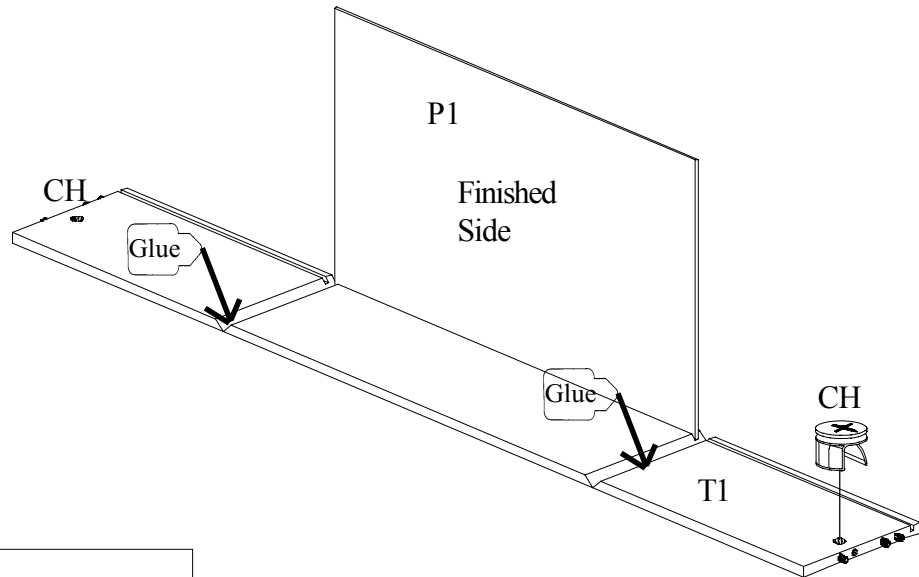
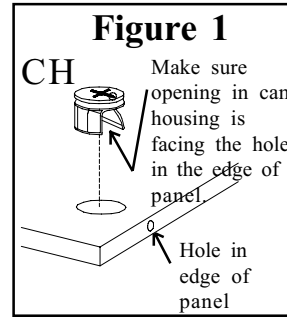

Handle Drawer Sides with Care

3

Parts needed for this step:

Drawer Front (G1), Drawer Sides (T1), Drawer Bottom (P1).

Hardware needed for this step:

Standard Flat-Head Screwdriver.

Action Required:

- * Place the dowels in the drawer sides (T1) into the holes in drawer front (G1). **Note Cam studs should align with holes in drawer sides (T1) and drawer bottom inserts into drawer front groove.**
- * Press down on the back of the drawer. If necessary, tap on drawer sides (T1), using a hammer against a block of wood wrapped in a protective cloth.
- * Wipe off excess glue with a damp cloth.
- * Lock cam housings with a half turn clockwise of a standard flat-head screwdriver.

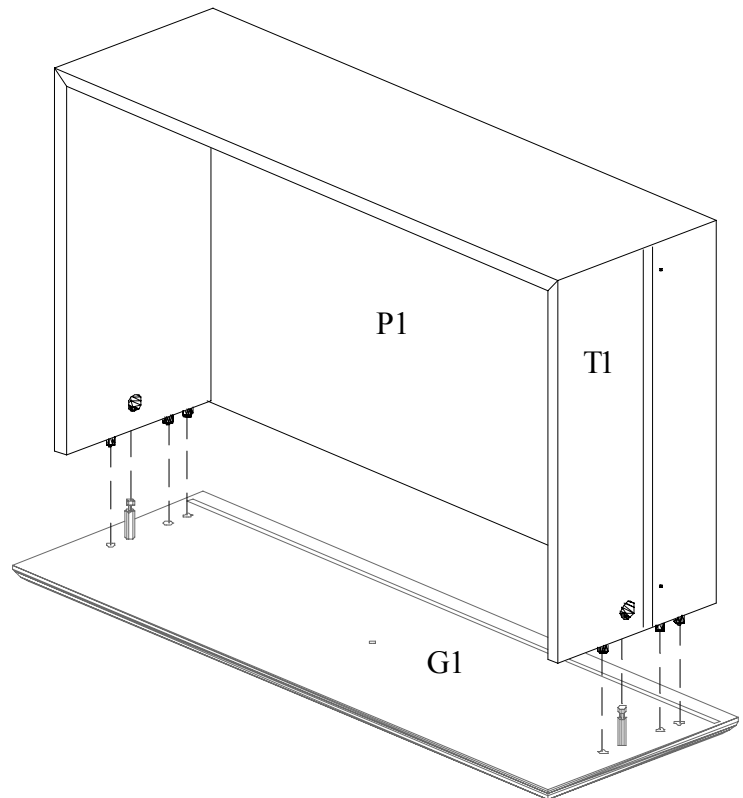
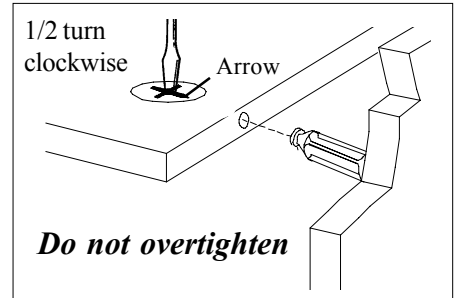

4 **Parts needed for this step:**
Drawer Assembly (G1, T1 & P1).

Hardware needed for this step:
Drawer Guides stamped "DR" and "DL",
(4) 1/2" Flat-Head Screws (S3), Knob,
7/8" Hardware Bolt.

Action Required:

Note: There is a right drawer guide (stamped "DR") and a left drawer guide (stamped "DL").

* Attach drawer guides to drawer sides (T1), with rollers facing toward the back, using (2) screws (S3) in each drawer guide. The drawer guides have a lip on one edge. The lip goes toward the top of the drawer, as shown.

* Attach knob to drawer (G1), using 7/8" hardware bolt.

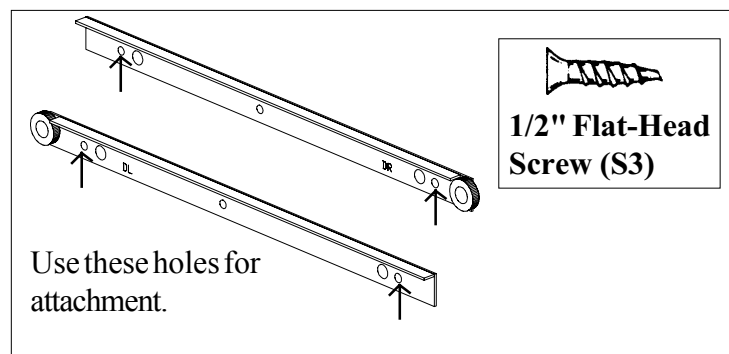
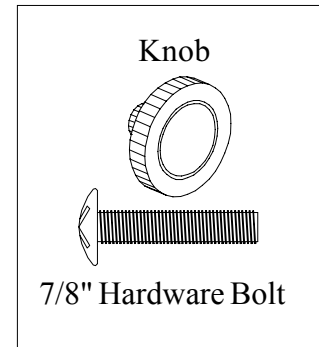
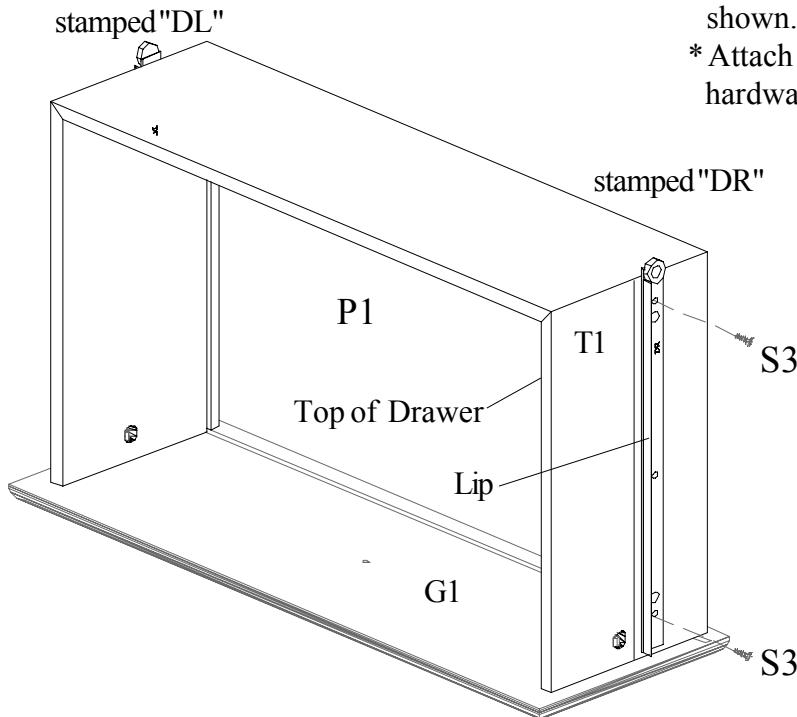

Follow Steps 1-4 for remaining Drawers (G1 and G).

5

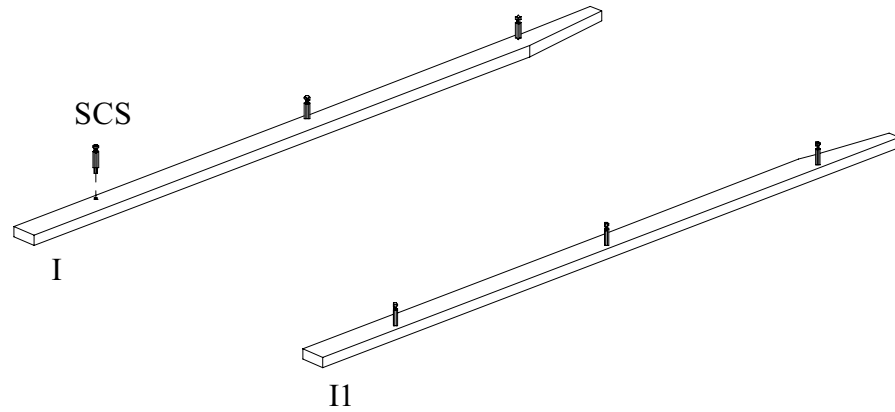
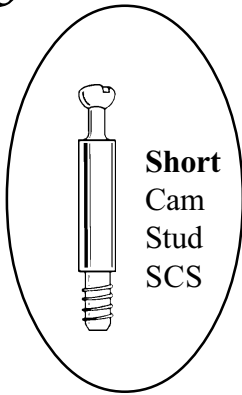

Parts needed for this step:

Left Vertical Rail (I), Right Vertical Rail (II).

Hardware needed for this step:

(6) Short Cam Studs (SCS).

Action Required:

* Screw (6) **short** cam studs (SCS) into the holes, as shown, in left and right vertical rails (I & II).

6

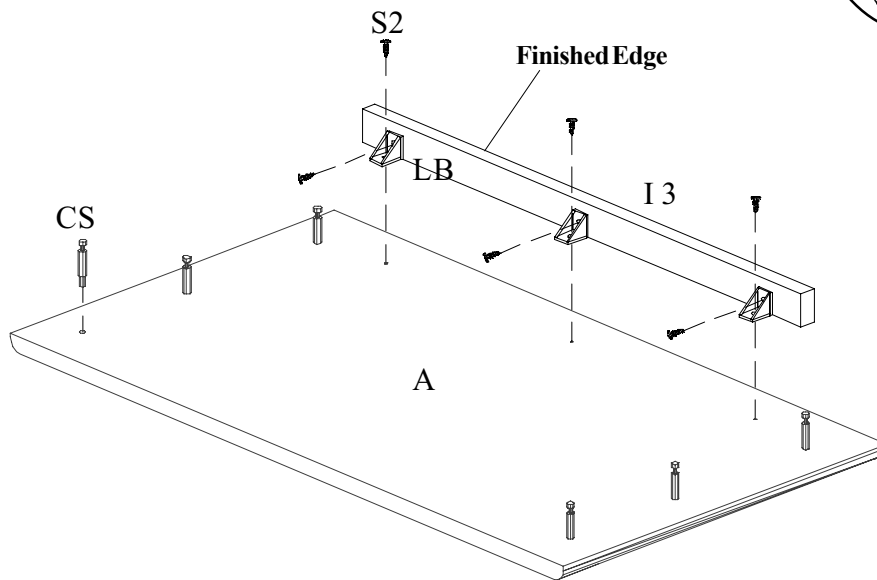
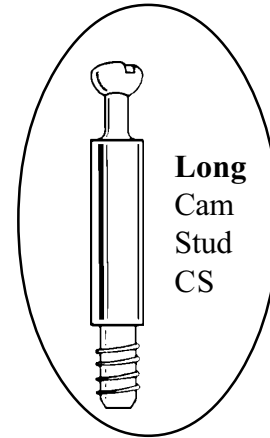
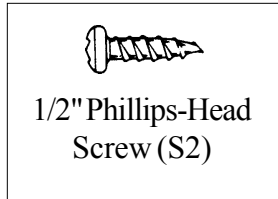

Parts needed for this step:

Top (A), Top Front Rail (I3).

Hardware needed for this step:

(3) L-Brackets (LB), (6) 1/2" Phillips-Head Screws (S2), (6) **Long** Cam Studs (CS).

Action Required:

- * Align the holes in rail (I3) with the holes in top (A) for proper placement of L-brackets (LB).
- * Attach (3) L-brackets (LB) to rail (I3), using (3) screws (S2).
- * **Loosely**, attach rail (I3) to top (A), using (3) screws (S2).
- * Screw (6) **long** cam studs (CS) into the holes, as shown, in top (A).

7

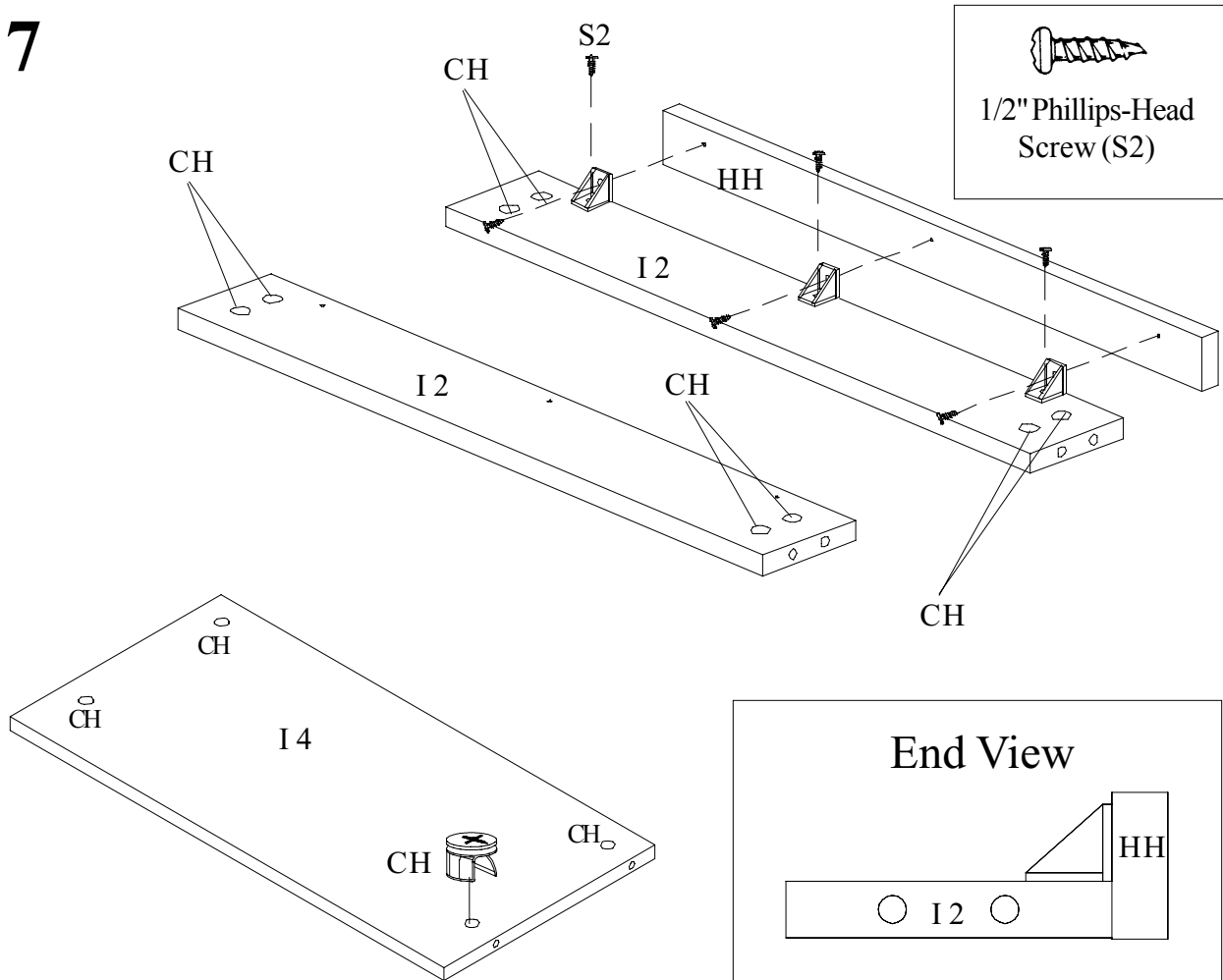

Parts needed for this step:

(2) Bottom Rails (I 2), Bottom Front Rail (HH),
Support Shelf (I 4).

Hardware needed for this step:

(3) L-Brackets (LB), (6) 1/2" Phillips-Head Screws (S2),
(12) Cam Housings (CH).

Action Required:

- * **SEE FIGURE 1**...Insert (12) cam housings (CH) into the holes, as shown, in bottom rails (I 2) and support shelf (I 4).
- * Align the holes in rail (HH) with the holes in bottom rail (I 2) for proper placement of L-brackets (LB). **Note: There is only one bottom front rail (HH) attached to bottom rail (I 2).**
- * Attach (3) L-brackets (LB) to bottom rail (I 2), as shown, using (3) screws (S2).
- * **Loosely**, attach rail (HH) to bottom rail (I 2), using (3) screws (S2).
Note: Small holes are not used in the other bottom rail (I 2).

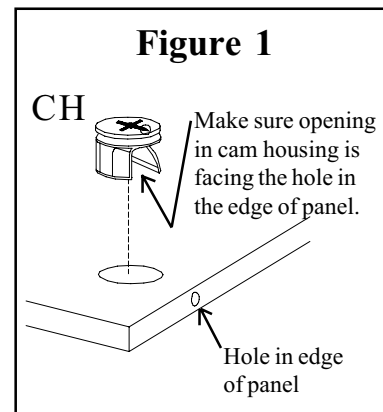

8

Parts needed for this step:

Left Side (D), Right Side (C).

Hardware needed for this step:

(12) **Long** Cam Studs (CS), (12) Cam Housings (CH).

Action Required:

* Screw (12) **long** cam studs (CS) into the holes, as shown, in left and right sides (D & C).

* Insert (12) cam housings (CH) into the holes, as shown, in left and right sides (D & C).

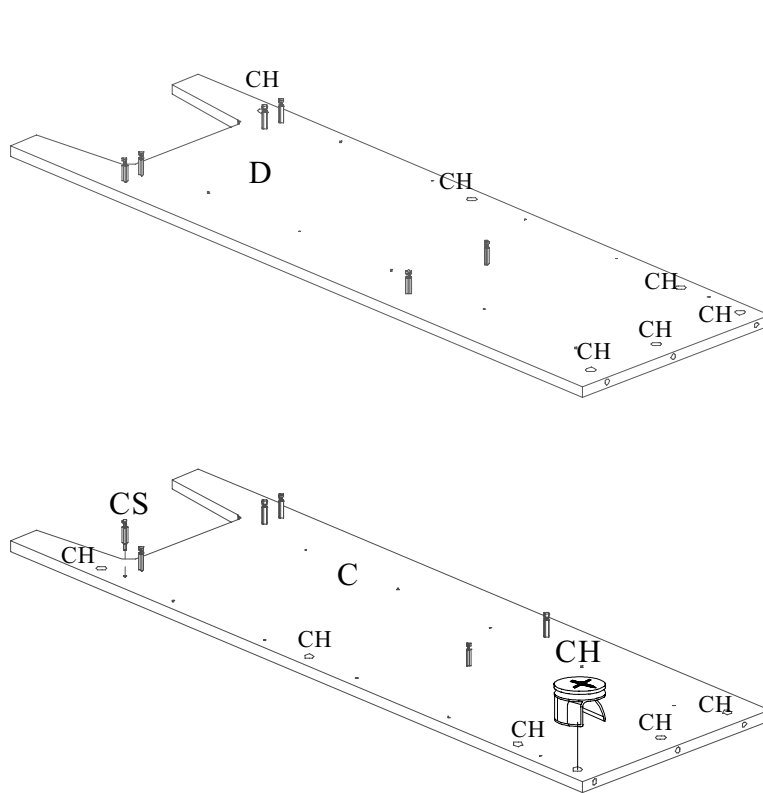

9

Parts needed for this step:
Left Side (D), Right Side (C).

Hardware needed for this step:
(20) Guide Spacers (GS), (20) 1/2" Phillips-Head Screws (S2).

Action Required:

* **SEE HELPFUL HINT...Securely**, attach (20) guide spacers (GS) to left side (D) and right side (C), as shown, using (20) screws (S2).

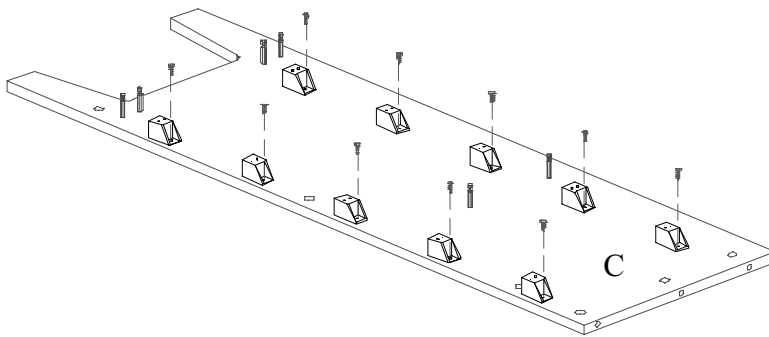
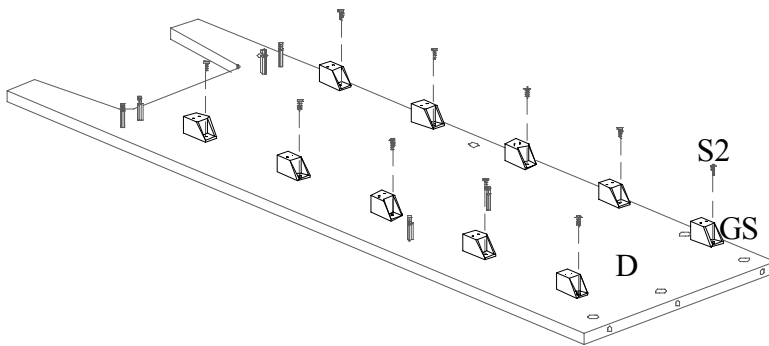
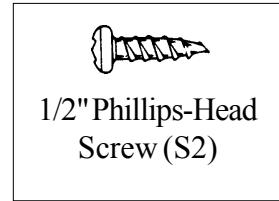

Helpful Hint...

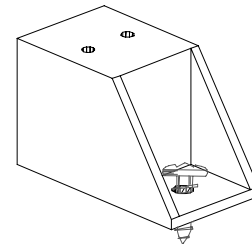

Start screw (S2) in Guide Spacers (GS), before attaching to sides, to ensure proper alignment of the screw with predrilled holes in sides (D & C).

10

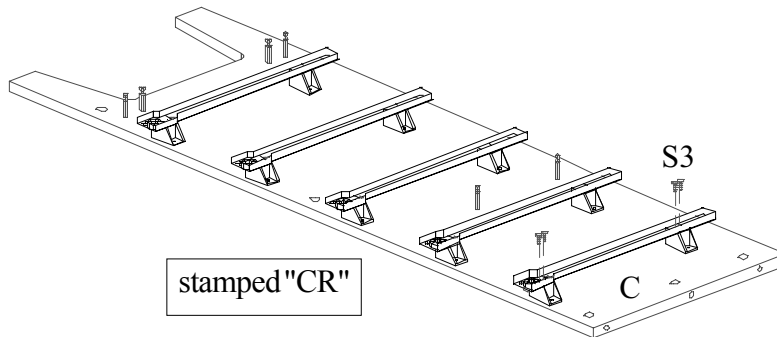
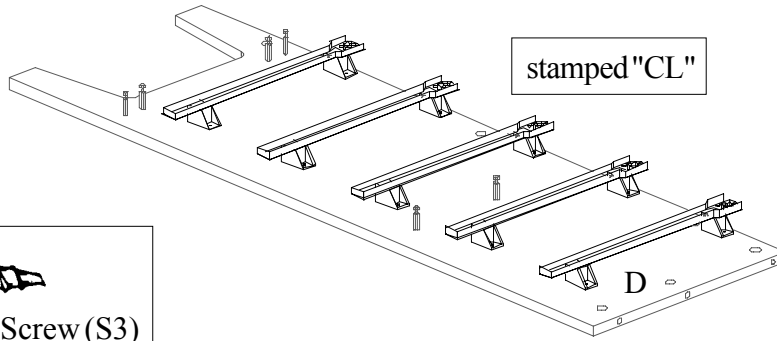
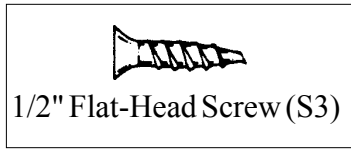

Helpful Hint...
Hold guide spacers with one hand while attaching drawer guides to prevent spacers from rotating.

Parts needed for this step:
Left Side (D), Right Side (C).

Hardware needed for this step:
(5) Drawer Guides (stamped "CL"), (5) Drawer Guides (stamped "CR"), (40) 1/2" Flat-Head Screws (S3).

Action Required:

Note: There is a left and a right drawer guide. The guides stamped "CL" will be attached to left side (D) and the guides stamped "CR" will be attached to right side (C).

* SEE FIGURE 2... AND HELPFUL HINT...attach drawer guides to guide spacers (GS), using (4) screws (S3) in each guide.

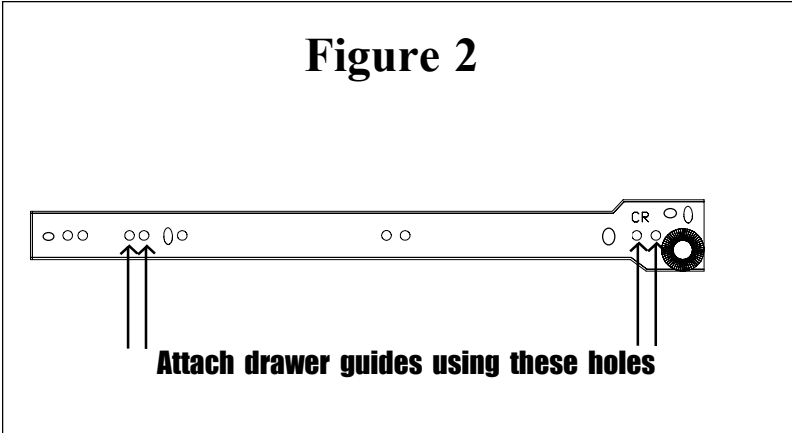

11

Parts needed for this step:

Left Side (D), Right Side (C), Support Shelf (I 4), (2) Bottom Rails (I 2).

Hardware needed for this step:

Standard Flat-Head Screwdriver.

Action Required:

- * Place left side (D) on its back edge, as shown.
- * **Note: Small holes in the lower bottom rail (I 2) should be up, as shown.** Attach bottom rails (I 2) to left side (D).
- * Lock cam housings with a half turn clockwise, using a standard flat-head screwdriver. **DO NOT OVERTIGHTEN.**
- * **SEE HELPFUL HINT...** Attach support shelf (I 4) to left side (D).
- * Lock cam housings. **DO NOT OVERTIGHTEN.**
- * Attach right side (C) to support shelf (I 4) and bottom rails (I 2).
- * Lock cam housings. **DO NOT OVER-TIGHTEN.**

HELPFUL HINT...
Back edge of shelf (I 4) should be flush with back edge of left and right sides (D & C).

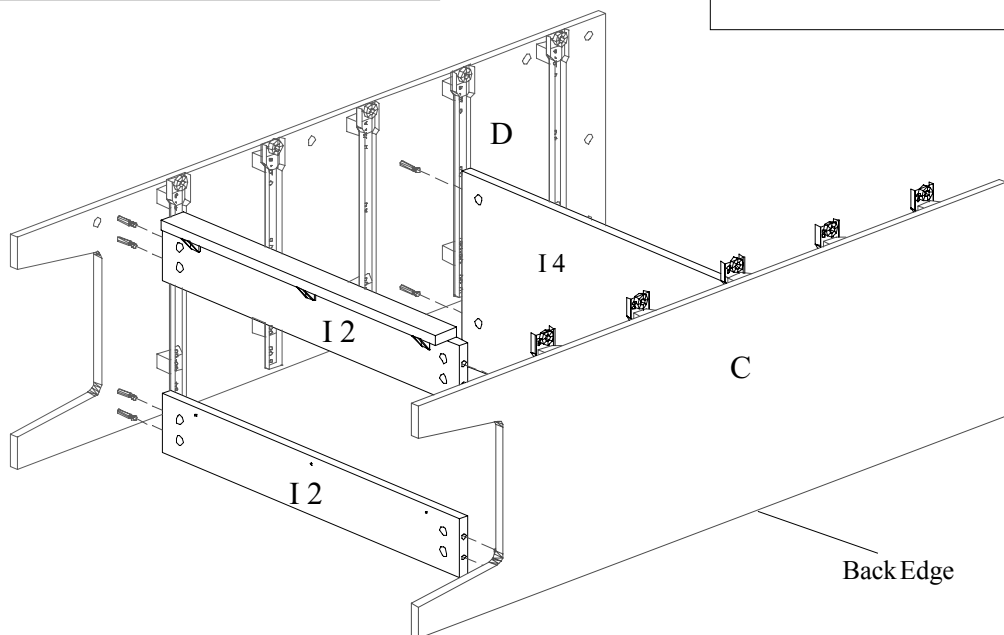
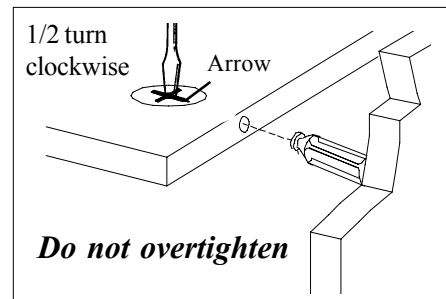

12

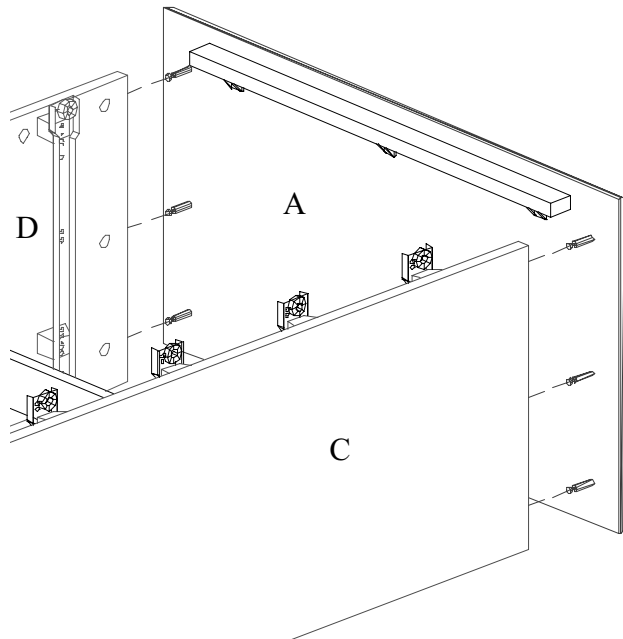

Parts needed for this step:

Top (A).

Hardware needed for this step:

Standard Flat-Head Screwdriver.

Action Required:

- * Place top (A) to left and right sides (D & C).
- * Lock cam housings with a half turn clockwise using a standard flat-head screwdriver.
DO NOT OVER-TIGHTEN.

13

Parts needed for this step:

Left Vertical Rail (I),
Right Vertical Rail (II).

Hardware needed for this step:

Standard Flat-Head Screwdriver.

Action Required:

- * Place left vertical rail (I) to left side (D).
- * Place right vertical rail (II) to right side (C).
- * Lock cam housings.
- * Tighten screws in L-Brackets in top front rail (I3) and bottom front rail (HH).

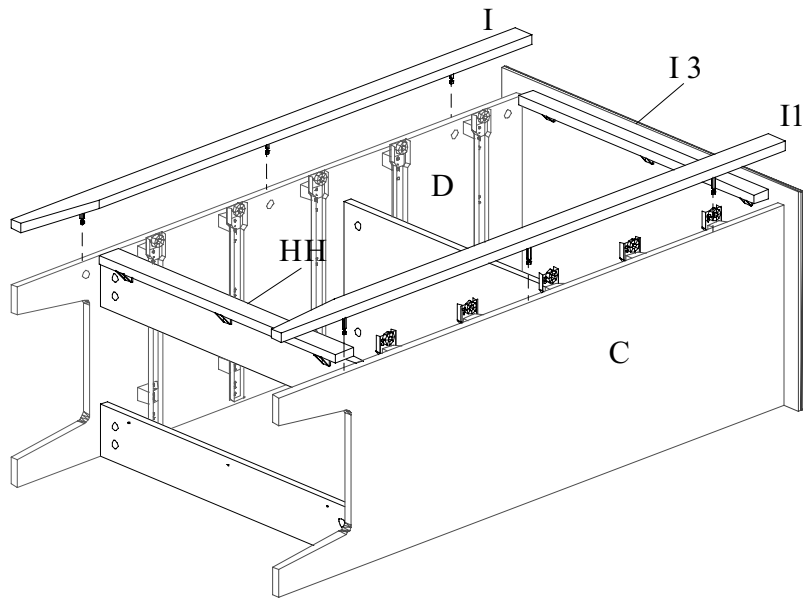

14

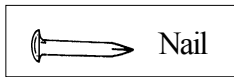
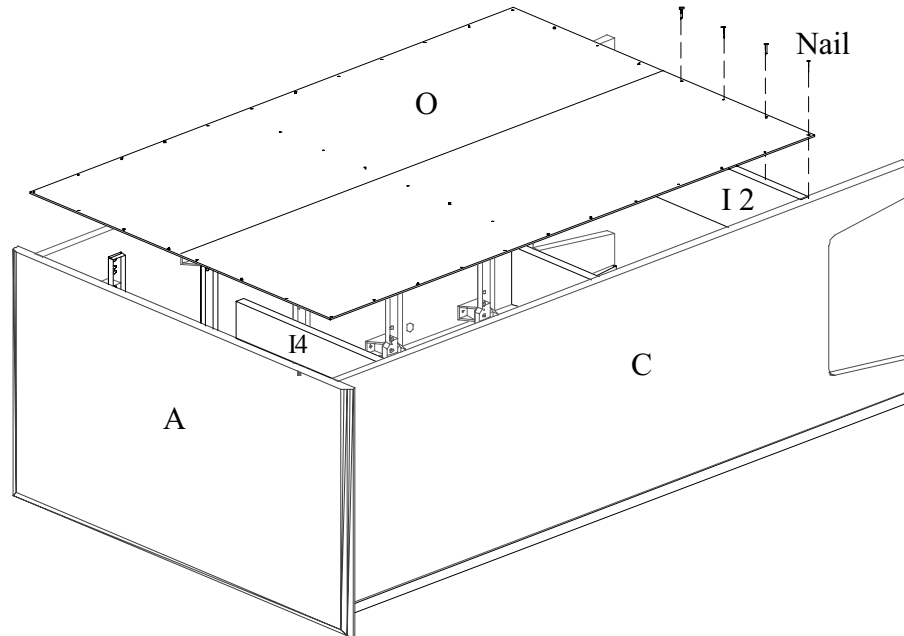

Note: Back panel adds stability to case.

Parts needed for this step:

Back Panel (O).

Hardware needed for this step:

Nails.

Action Required:

- * With a helper, carefully turn unit over with the front against the floor.
- * Position back panel (O) even with the bottom edge of bottom rail (I2) and holes align with back edge of support shelf (I4).
- * Make sure panel (O) fits square and even side to side. **If it doesn't, adjust unit into square by pushing or pulling on one corner of the unit until back panel fits squarely.**
- * While nailing into pilot holes, take care to hammer nails in straight.

Note: Make sure all cam housings are in the locked position.

15

Install the drawers. Drawers (G) are the upper two drawers. Drawers (G1) are the lower three drawers.

IMPORTANT

Do not exceed the recommended weight limit on the designated panel. Exceeding this limit could cause sagging, possibly resulting in failure of the top or bodily injury.

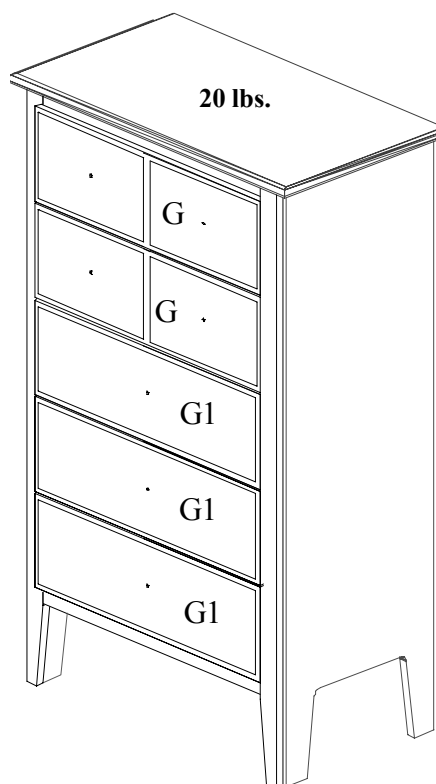

This unit is intended for storage only. Other uses may cause unit to tip.

16

* Decorative cover caps are provided to cover exposed cam housings.

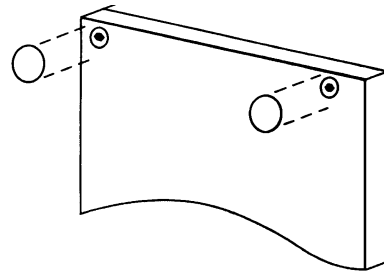

That's it! You've finished assembling your 5 Drawer Chest by



A **touch-up pen** has been provided for any touch up needed.

MRP- 80113216 (Carysbrook)
0904