

563-150

3 Drawer / 2 Door Dresser

Creative Interiors

(Carysbrook)

A DIVISION OF THOMASVILLE FURNITURE INDUSTRIES, INC

Assembly Instructions

**DO NOT CONTACT STORE FOR
PARTS OR ASSEMBLY ASSISTANCE**

Individual stores do not stock parts.

For Fast-Efficient-Friendly Service

Please call toll free: 1-800-782-3876 or
e-mail CISupport@Thomasville.com

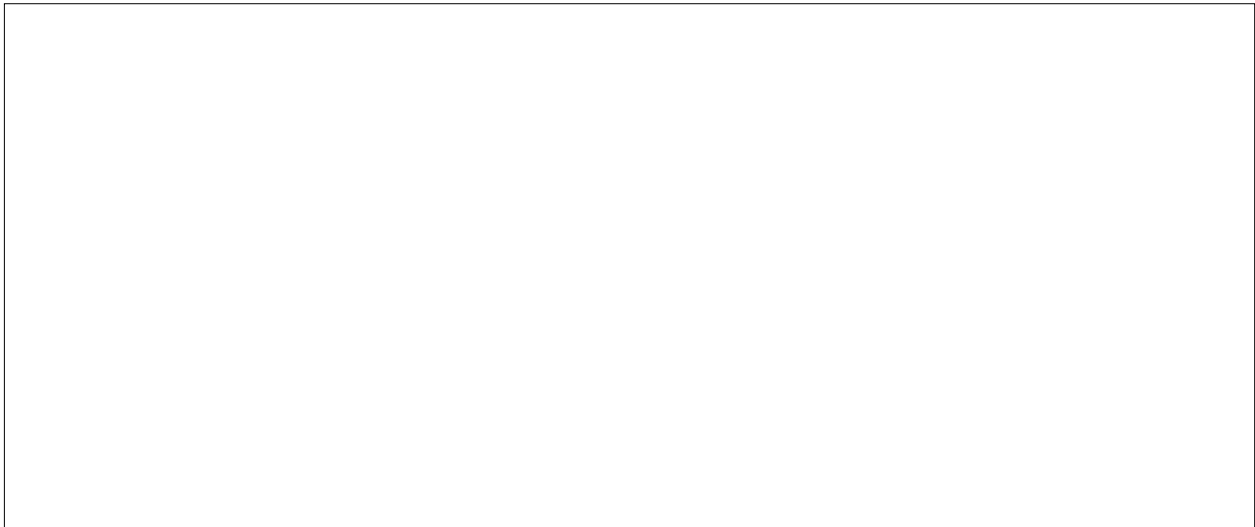

WARNING...This unit is to be used for storage only. Other uses may cause product to tip.

- * Do not allow anyone to climb on unit.
- * Put heavy items on lower drawers or shelves.
- * Open one drawer at a time.

Tools

You will need a regular screwdriver, Phillips head screwdriver and a hammer. We've included a hex wrench.

Parts List

Screws are shown actual size. Hardware may be shown smaller than actual size. Before you begin assembly, lay all pieces out on the floor according to these illustrations.

Note: For reasons of manufacturing efficiencies, you may find extra hardware and unused holes in parts.

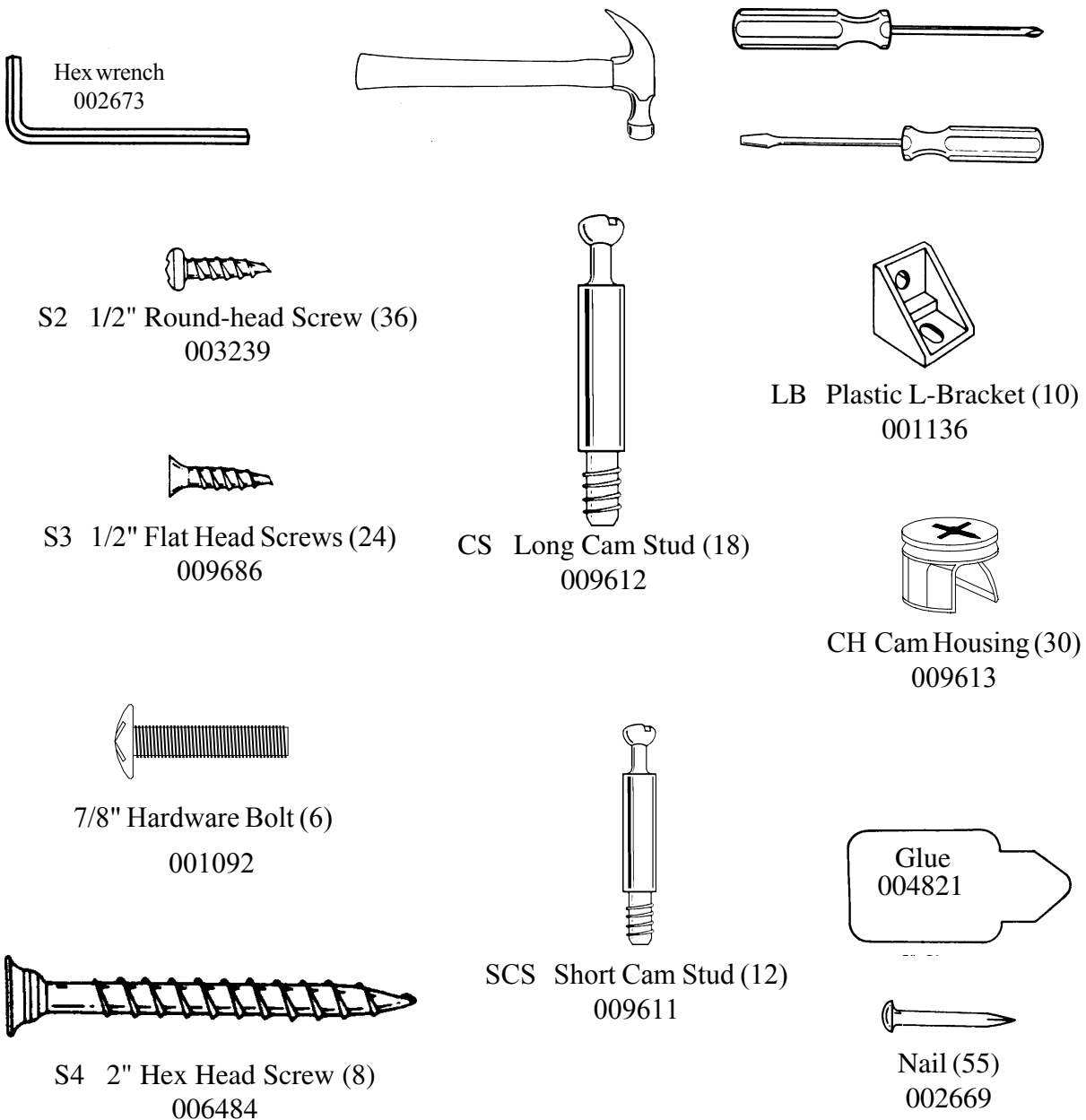



 Cover-cap (25)
 80112983

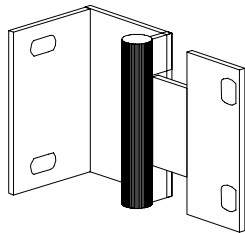

 KB Knob (6)
 80071756

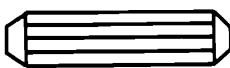
 LPN Locking Shelf Pins (16)
 004053

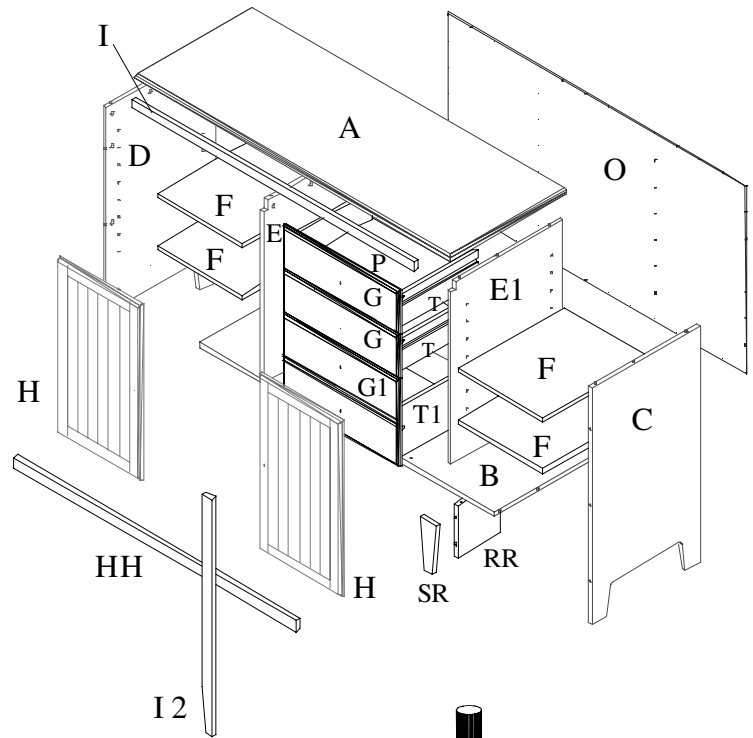

 HG Hinge (4)
 80071423

 WD Wooden Dowel (2)
 002314

I 1



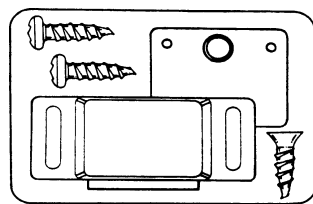

 Touch Up Pen (1)
 80113188

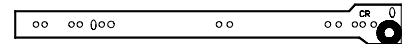

Magnetic Catch Set (2)
 MC Magnetic Catch,
 SP Strike Plate
 Screws
 008075

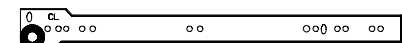
Drawer Guides

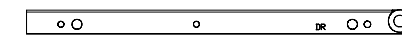
 007420 (3) stamped "CR"

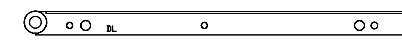

 007419 (3) stamped "CL"

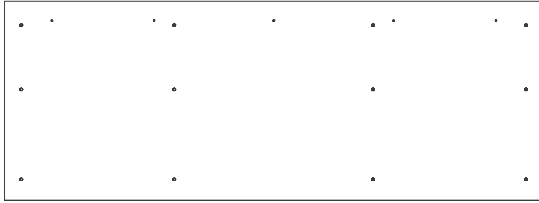
 007421 (3) stamped "DL"



 007422 (3) stamped "DR"

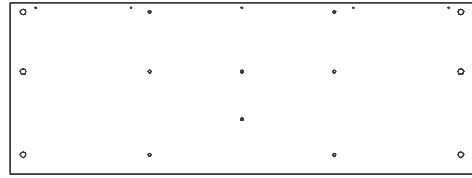

A Top (1)
53" x 19-1/2"
015321Z

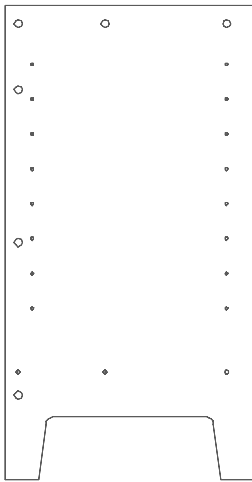

B Bottom (1)
49-1/16" x 18-1/8"
024903Z



D Left Side (1)
34-5/16" x 18-1/8"
043414Z

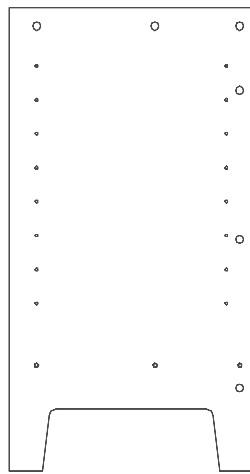

C Right Side (1)
34-5/16" x 18-1/8"
033414Z

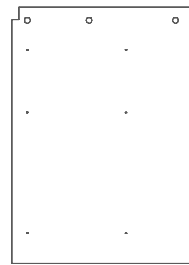

E Left Partition (1)
26-3/16" x 18-3/4"
052712Z



E1 Right Partition (1)
26-3/16" x 18-3/4"
052711Z

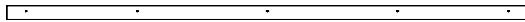

I Top Front Rail (1)
47-3/16" x 1-1/4"
094726Z

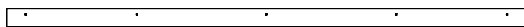

HH Bottom Front Rail (1)
47-3/16" x 1-5/8"
094727Z



I1 Left Vertical Rail (1)
34-1/4" x 1-5/8"
093446Z



I2 Right Vertical Rail (1)
34-1/4" x 1-5/8"
093445Z

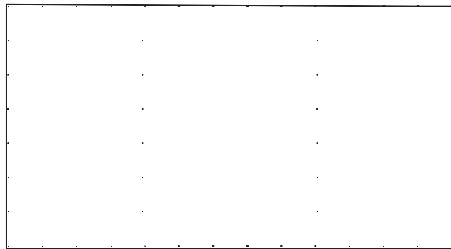

O Back Panel (1)
50-1/16" x 27-5/16"
80115406



SR Support Foot (1)
7-3/8" x 2-15/16"
090706Z

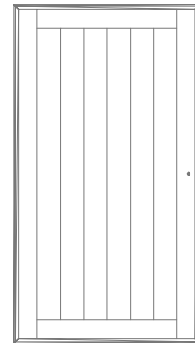

H Door (2)
25-3/8" x 13-15/16"
082513Z



G Upper Drawer (2)
19-7/16" x 6-1/4"
071923Z



RR Support (1)
7-7/16" x 7-7/16"
440707Z

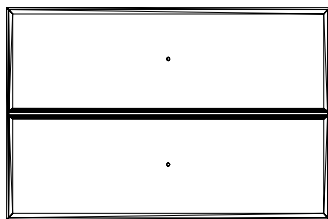

G1 Lower Drawer (1)
19-7/16" x 12-5/8"
071924Z

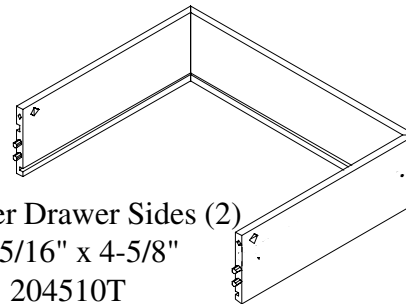

T Upper Drawer Sides (2)
45-5/16" x 4-5/8"
204510T



P Drawer Bottom (3)
17-3/8" x 13-9/16"
80085550

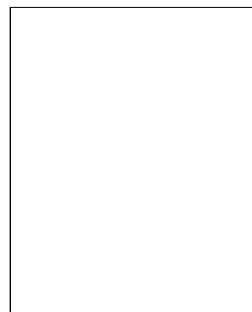

F Adjustable Shelf (4)
17-11/16" x 14-1/4"
061415Z

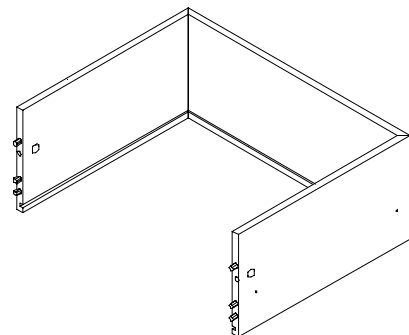

T1 Lower Drawer Sides (1)
45-5/16" x 7-1/8"
204511T

Note: All parts may not be identified with labels, but to help identify certain parts, you may see one or more types of labelling. One type is the peel-off label and the other is an ink-print on one of the unfinished edges.

**Drawer Assembly for (2) Drawers (G) and (1) Drawer (G1).
Follow Steps 1 - 6 for each drawer.**

1

Parts needed for this step:
Drawer (G).

Hardware needed for this step:
(2) **Short Cam Studs (SCS)**,
Glue.

Action Required:

- * Screw (2) **short** cam studs (SCS) into the holes, as shown, in drawer front (G).
- * Apply 2 - 3 drops of glue into each dowel hole in drawer front, but do not fill with glue.
- * Spread glue evenly on the inside of the holes with a toothpick or similar object.
- * Set aside.

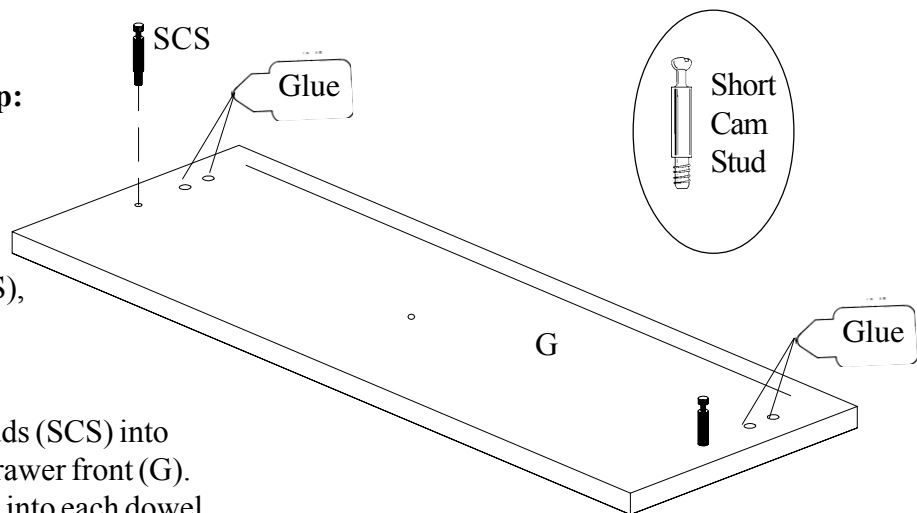

2

Parts needed for this step:

Drawer Sides (T), Drawer Bottom (P).

Hardware needed for this step:

(2) Cam Housings (CH), glue.

Action Required:

- * Place drawer sides (T) as shown in diagram.
- * **SEE FIGURE 1**...Insert (2) cam housings (CH) into the holes in drawer sides (T).
- * Apply glue into the corner joints of drawer sides (T).
- * Stand drawer bottom (P) in long groove, **finished side up**, and fold the drawer sides (T) up around the drawer bottom (P).

Handle Drawer Sides with Care

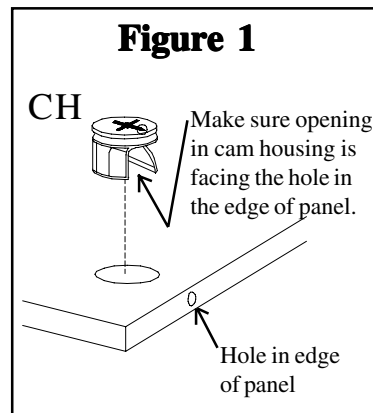
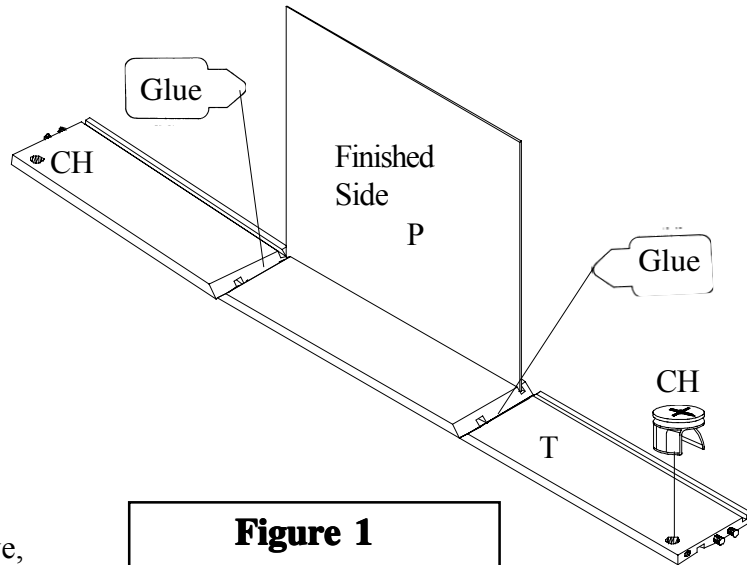

3

Parts needed for this step:

Drawer Sides (T), Drawer (G).

Hardware needed for this step:

Standard Flat-Head Screwdriver.

Action Required:

- * Place drawer front (G), as shown in diagram.
- * Place the dowels in the drawer sides (T) into the holes in drawer front (G).

Note: Cam studs should align with holes in drawer sides (T).

- * Press down on the back of the drawer. If necessary, turn drawer with drawer front up and tap on drawer front, using a hammer against a block of wood wrapped in a protective cloth.

Note: Make sure drawer bottom inserts into drawer front groove.

- * Wipe off excess glue with a damp cloth.
- * Lock cam housings with a half turn clockwise of a standard flat-head screwdriver.

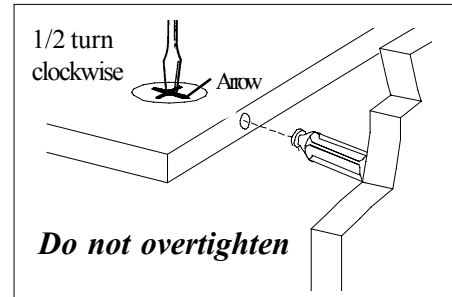
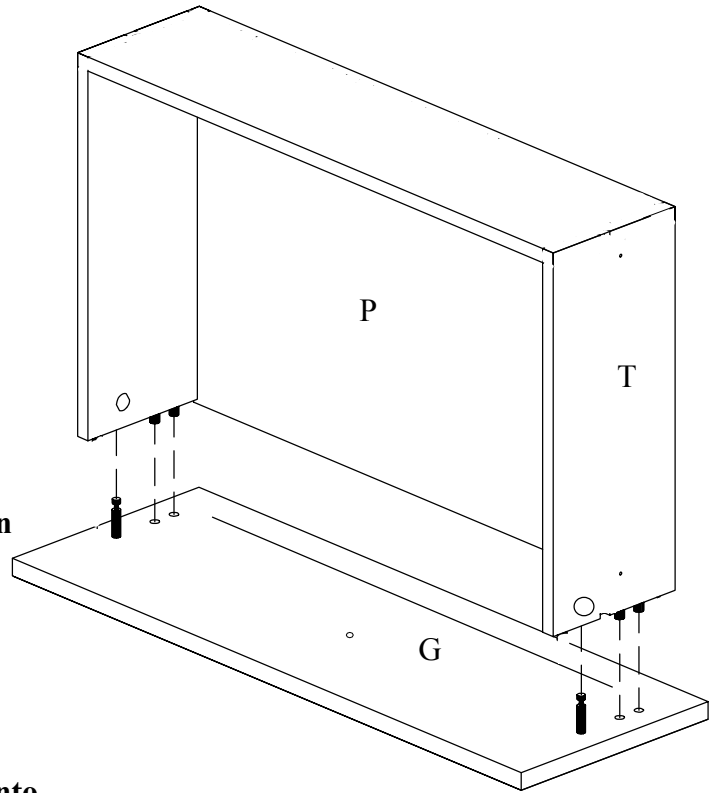

4

Hardware needed for this step:

Drawer Guide stamped "DR",
Drawer Guide stamped "DL",
(4) Flat-Head Screws (S3).

Action Required:

Note: There is a right drawer guide (stamped "DR") and a left drawer guide (stamped "DL").

* Attach drawer guides to drawer sides (T), with rollers facing toward the back, using (2) **flat-head** screws (S3) in each drawer guide. The drawer guides have a lip on one edge. The lip goes toward the top of the drawer, as shown.

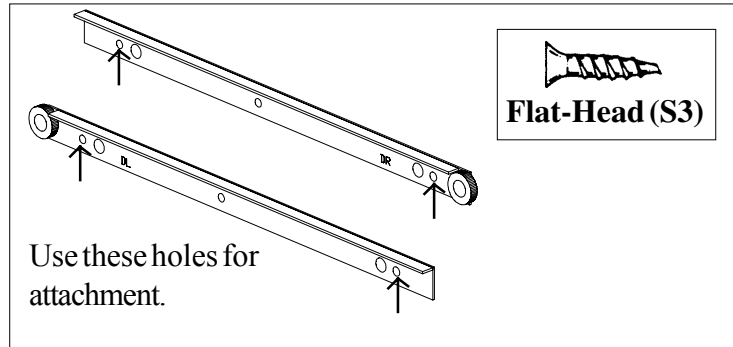
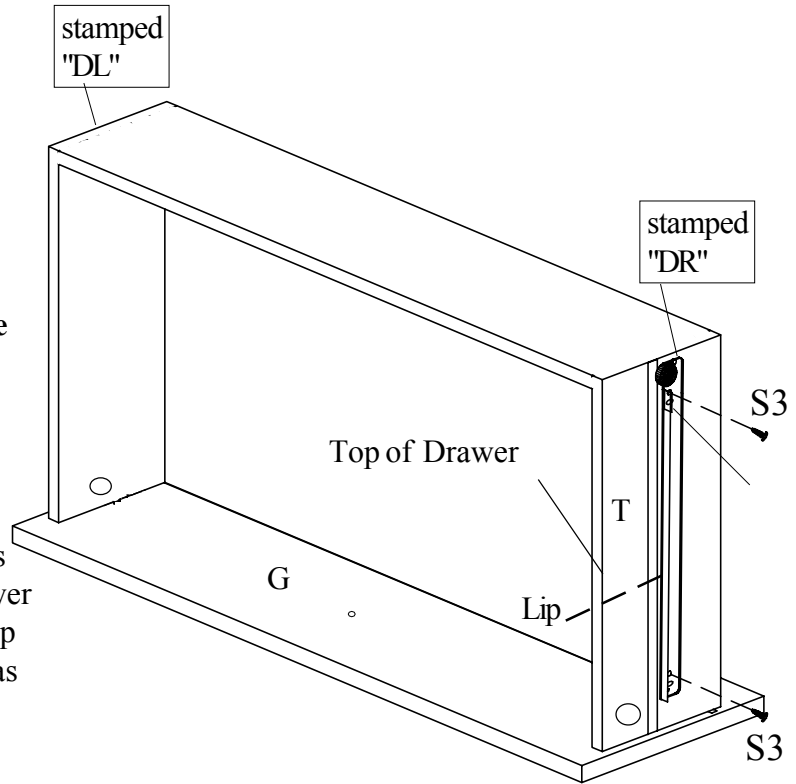

5 * Repeat Steps 1-4 for other Drawer (G) and Drawer (G1).

6 **Hardware needed for this step:**
(4) Knobs (KB), (4) 7/8" Hardware Bolts.

Action Required:

* Attach knobs to drawers (G & G1), using (4) 7/8" hardware bolts.

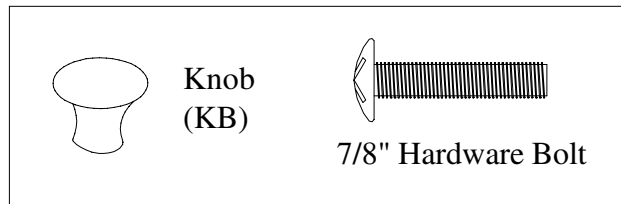

7 **Subassembly**

Parts needed for this step:
Left Vertical Rail (I1), Right Vertical Rail (I2).

Hardware needed for this step:
(6) Short Cam Studs (SCS).

Action Required:

* Screw (6) short cam studs (SCS) into the holes, as shown, in rails (I 1 & I 2).

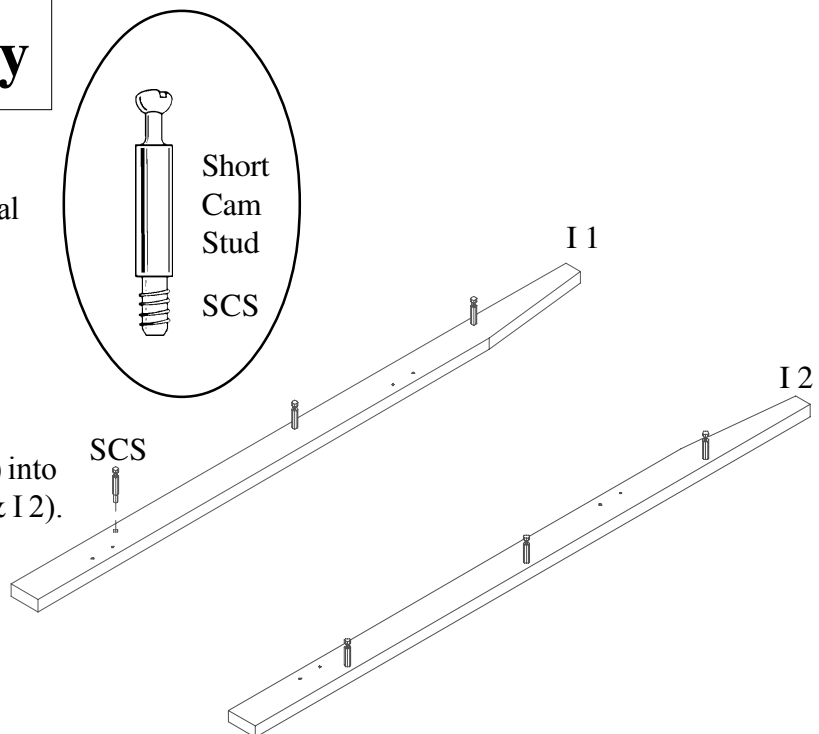

8

Parts needed for this step:

Left Vertical Rail (I1), Right Vertical Rail (I2).

Hardware needed for this step:

(4) Hinges (HG), (8) Round-Head Screws (S2).

Action Required:

* Attach (4) hinges (HG) to rails (I 1 & I 2), **slots as shown**, using (8) round-head screws (S2).

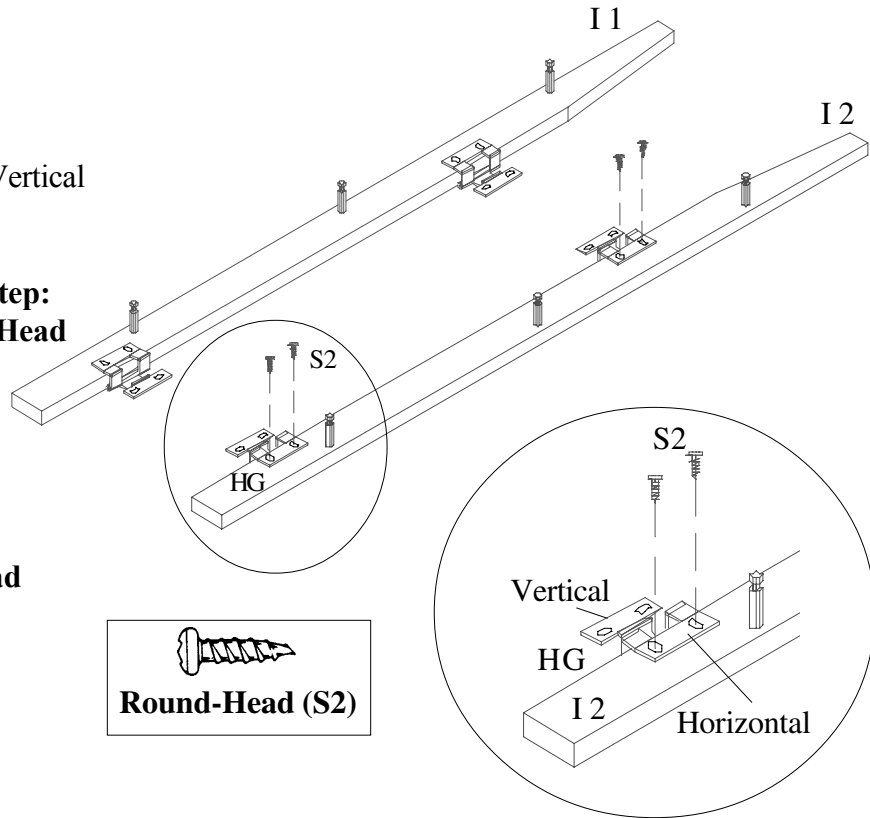

9

Parts needed for this step:

Top (A), Top Front Rail (I).

Hardware needed for this step:

(12) Long Cam Studs (CS), (5) L-Brackets (LB), (10) Round-Head Screws (S2).

Action Required:

* Screw (12) long cam studs (CS) into the holes, as shown, in top (A).

* Attach (5) L-Brackets (LB) to top front rail (I), using (5) round-head screws (S2).

* Attach top front rail (I), **finished edge up**, to top (A) using (5) round-head screws (S2).

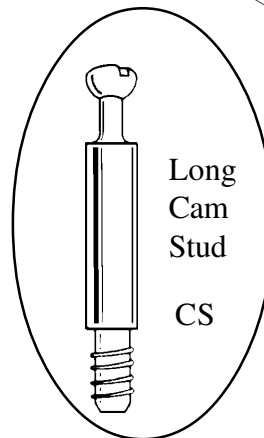
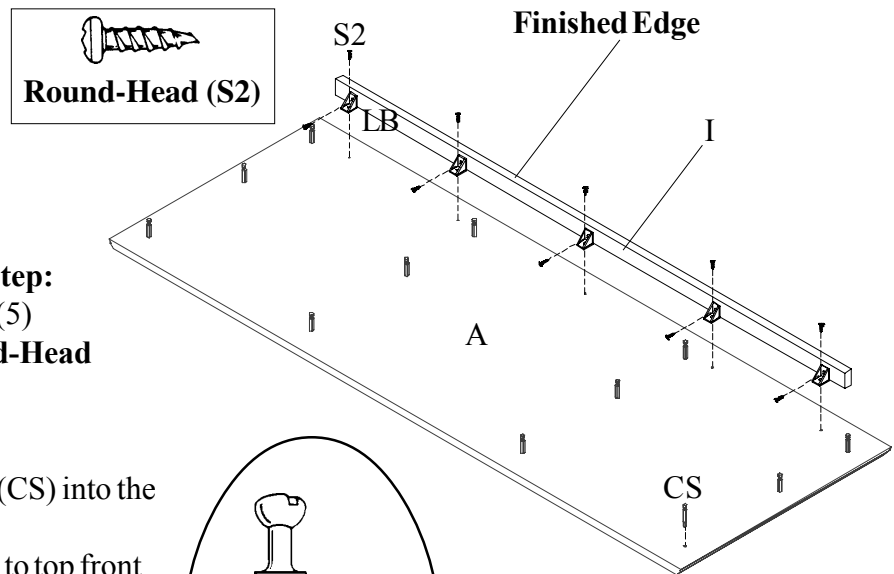

10

Parts needed for this step:

Support (RR), Support Foot (SR).

Hardware needed for this step:

(2) Wooden Dowels (WD), Hammer.

Action Required:

- * *Apply 2-3 drops of glue into the two dowel holes in the outer edge of support (RR); do not fill with glue. Carefully tap (2) wooden dowels (WD) into the outer holes, as shown, in support (RR).*

Note: Leave approximately 3/8" of the dowels sticking out.

- * *Apply 2-3 drops of glue into the two dowel holes in support foot (SR); do not fill with glue.*

- * Place support foot (SR) to support (RR), as shown. If necessary, tap on support foot (SR), using a hammer against a block of wood wrapped in a protective cloth.

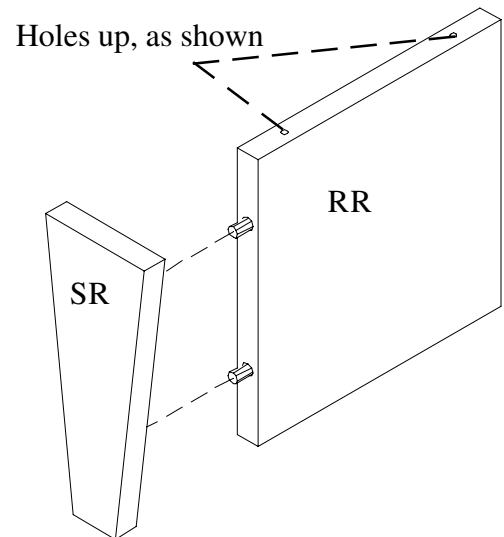
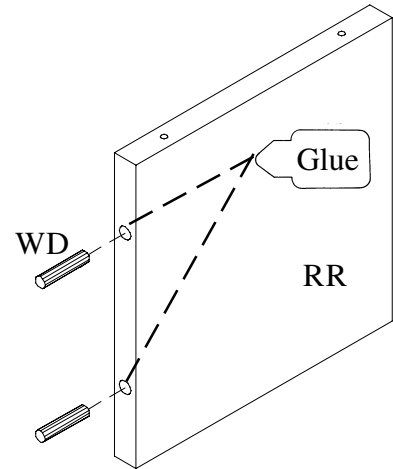
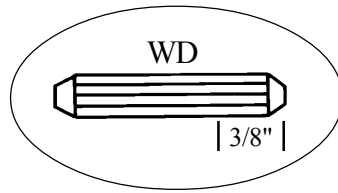

11

Parts needed for this step:

Bottom (B), Bottom Front Rail (HH), Support (RR) with Support Foot.

Hardware needed for this step:

(6) Cam Housings (CH), (5) L-Brackets (LB), (10) **Round-Head** Screws (S2), (2) Hex-Head Screws (S4), Hex-Wrench (provided).

Action Required:

- * **SEE FIGURE 1**...Insert (6) cam housings (CH) into the holes, as shown, in bottom (B).
- * Attach (5) L-Brackets (LB) to bottom (B), using (5) **round-head** screws (S2).
- * **SEE FIGURE 2**...Attach bottom front rail (HH) to bottom (B), using (5) **round-head** screws (S2).
- * Attach support (RR) to bottom (B), using (2) hex-head screws (S4). Hex-wrench is provided.

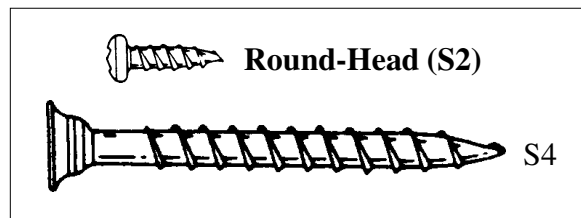
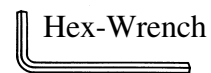
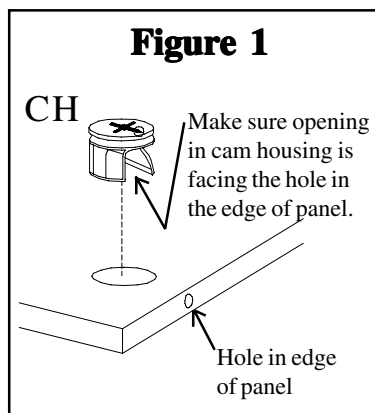
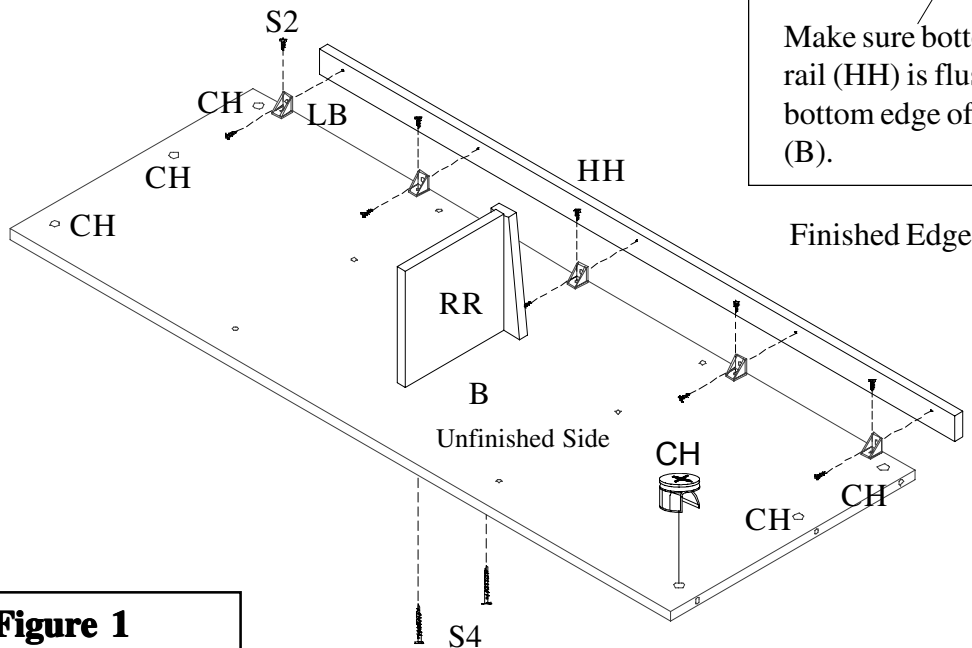
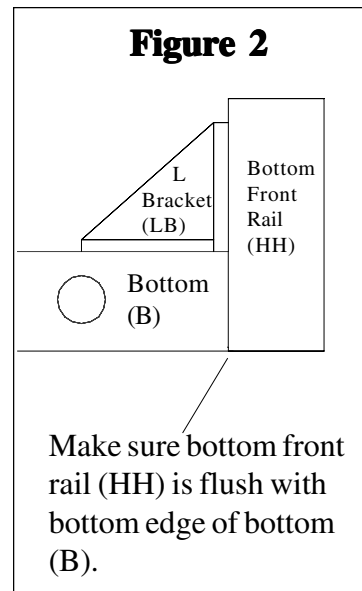

12

Parts needed for this step:

Left Side (D), Right Side (C).

Hardware needed for this step:

(6) Long Cam Studs (CS), (12) Cam Housings (CH).

Action Required:

- * Screw (6) long cam studs (CS) into the holes, as shown, in sides (D & C).
- * Insert (12) cam housings (CH) into the holes, as shown, in sides (D & C).

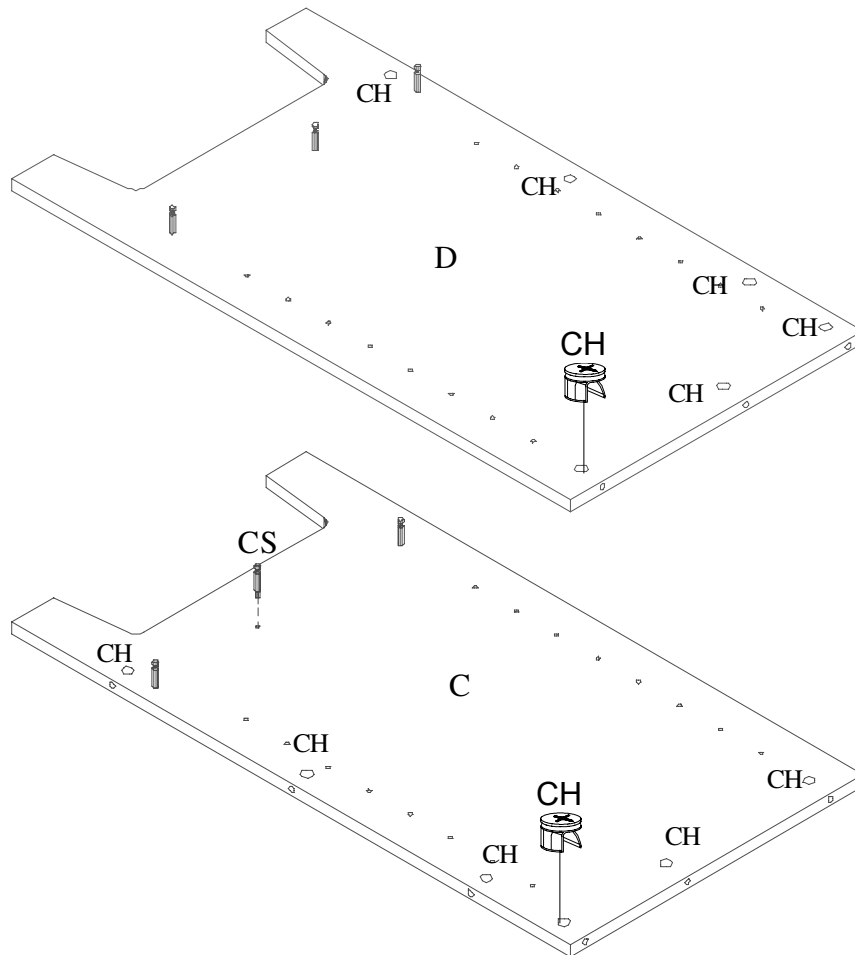

13

Parts needed for this step:

Left Partition (E), Right Partition (E1).

Hardware needed for this step:

(3) Drawer Guides stamped "CL",
(3) Drawer Guides stamped "CR",
(12) **Flat-Head** Screws (S3), (6) Cam
Housings (CH).

Action Required:

**Note: There is a left and a right
drawer guide. The guide stamped
"CL" will be attached to
partition (E) and the guide
stamped "CR" will be
attached to partition (E1).**

- * **SEE FIGURE 3**...attach drawer guides to partitions (E & E1), using (2) **flat-head** screws (S3) in each guide.
- * Insert (6) cam housings (CH) into the holes, as shown, in partitions (E & E1).

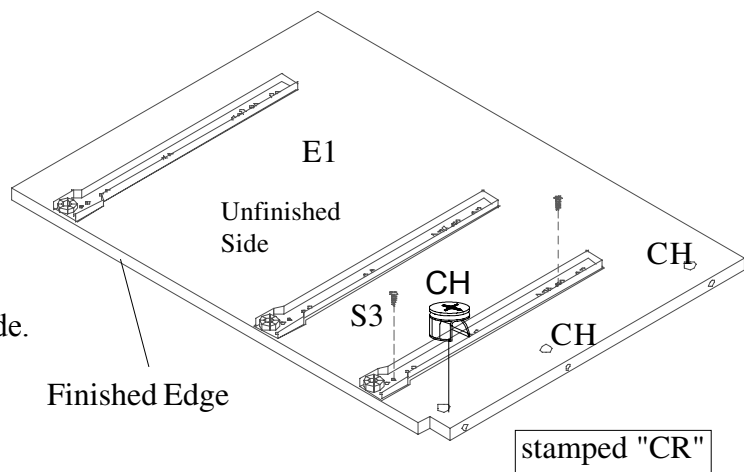
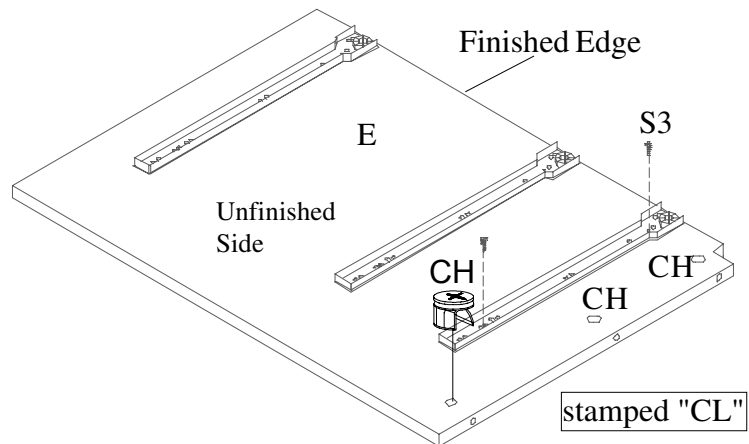
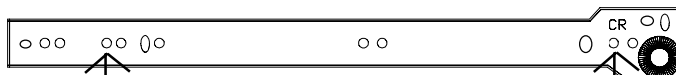

Figure 3



Attach drawer guides using these holes



Main Assembly

14

Parts needed for this step:

Bottom (B), Left Partition (E), Right Partition (E1).

Hardware needed for this step:

(6) Hex-Head Screws (S4),
Hex-Wrench (provided).

Action Required:

- * Attach partitions (E & E1), **finished edge up**, to bottom (B), using (6) Hex-Head screws (S4). Hex-wrench is provided.

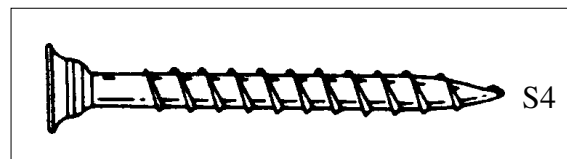
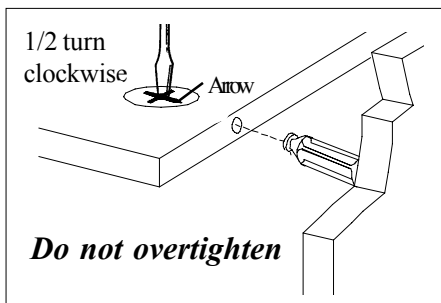
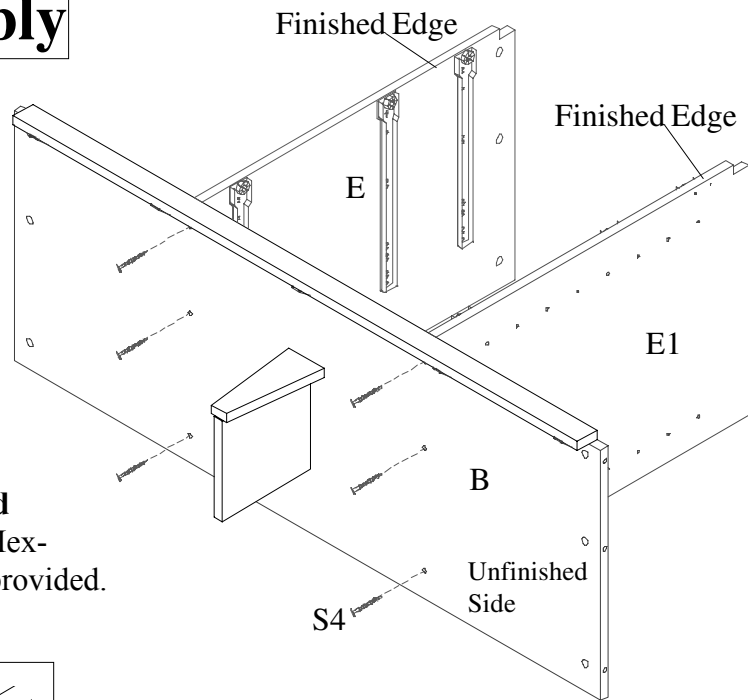

15

Parts needed for this step:

Left Side (D), Right Side (C).

Hardware needed for

this step:

Standard Flat-Head
Screwdriver.

Action Required:

- * Attach sides (D & C) to bottom (B), as shown.
- * Lock cam housings in bottom (B) with a half turn clockwise of a standard flat-head screwdriver.

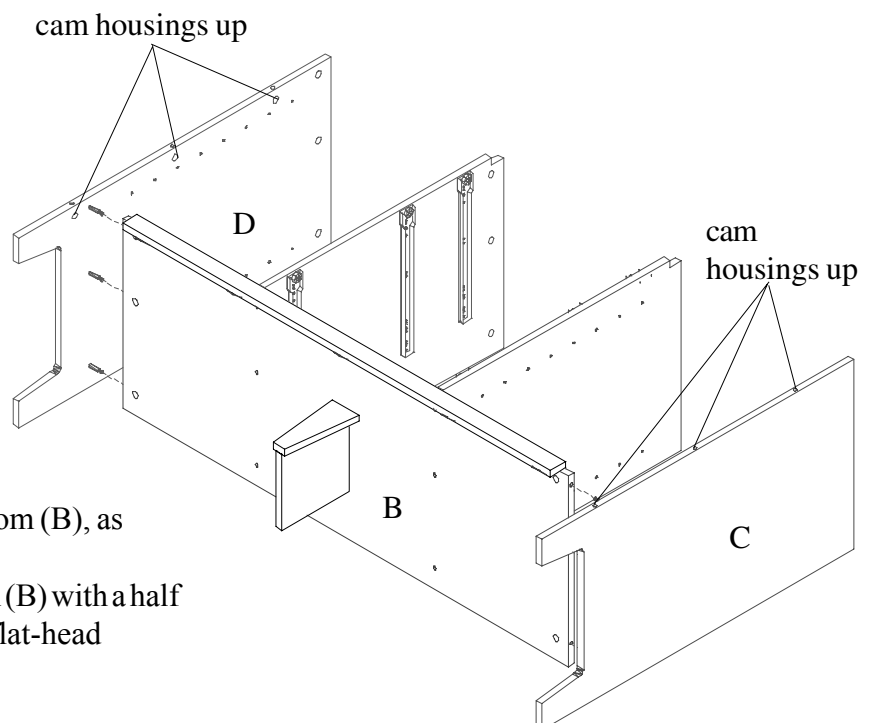

16

Parts needed for this step:

Top (A).

Hardware needed for this

step:

Standard Flat-Head
Screwdriver.

Action Required:

- * With a helper, attach top (A) to sides (D & C) and partitions (E & E1).
- * Lock cam housings with a half turn clockwise of a standard flat-head screwdriver.

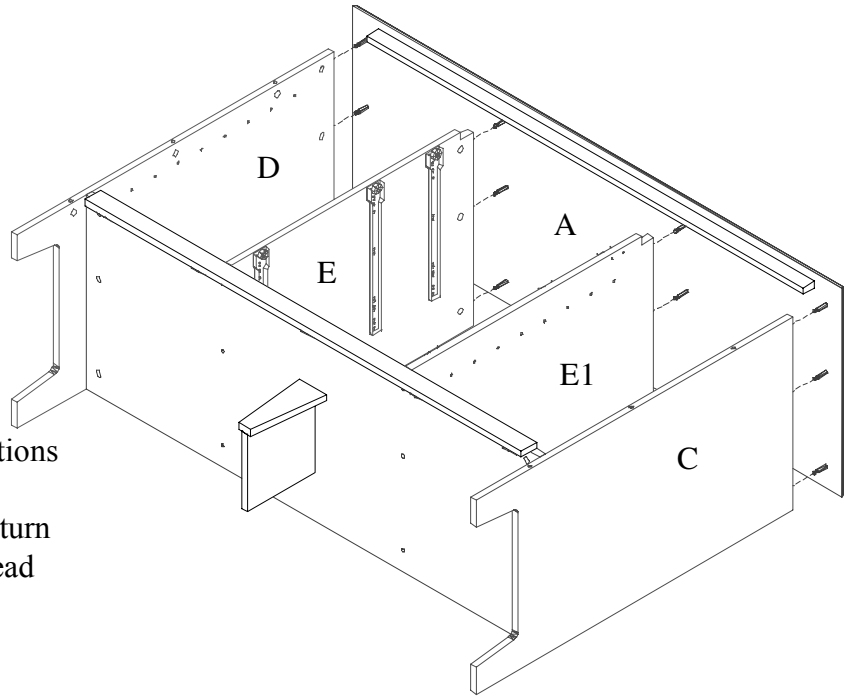

17

Parts needed for this step:

Left Vertical Rail (I1), Right Vertical Rail (I2).

Hardware needed for this step:

Standard Flat-Head Screwdriver,
Phillips-Head Screwdriver.

Action Required:

- * Attach rail (I 1) to side (D).
- * Lock cam housings.
- * Attach rail (I 2) to side (C).
- * Lock cam housings.
- * *If necessary, adjustment may be made to top front rail (I) and bottom front rail (HH) by loosening screws in L-Brackets, adjusting and retightening.*

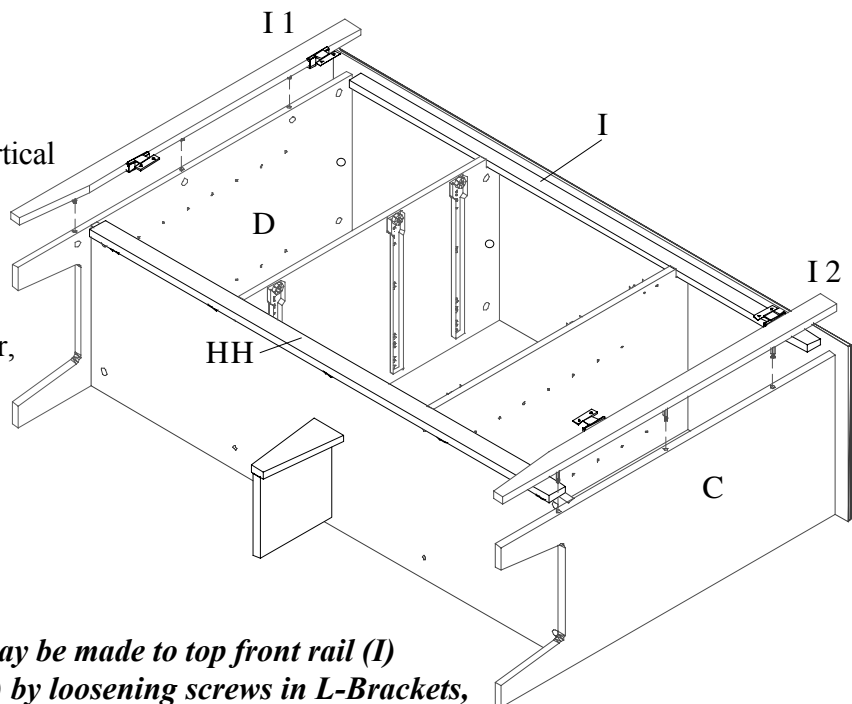

Note: Back panel adds stability to case.

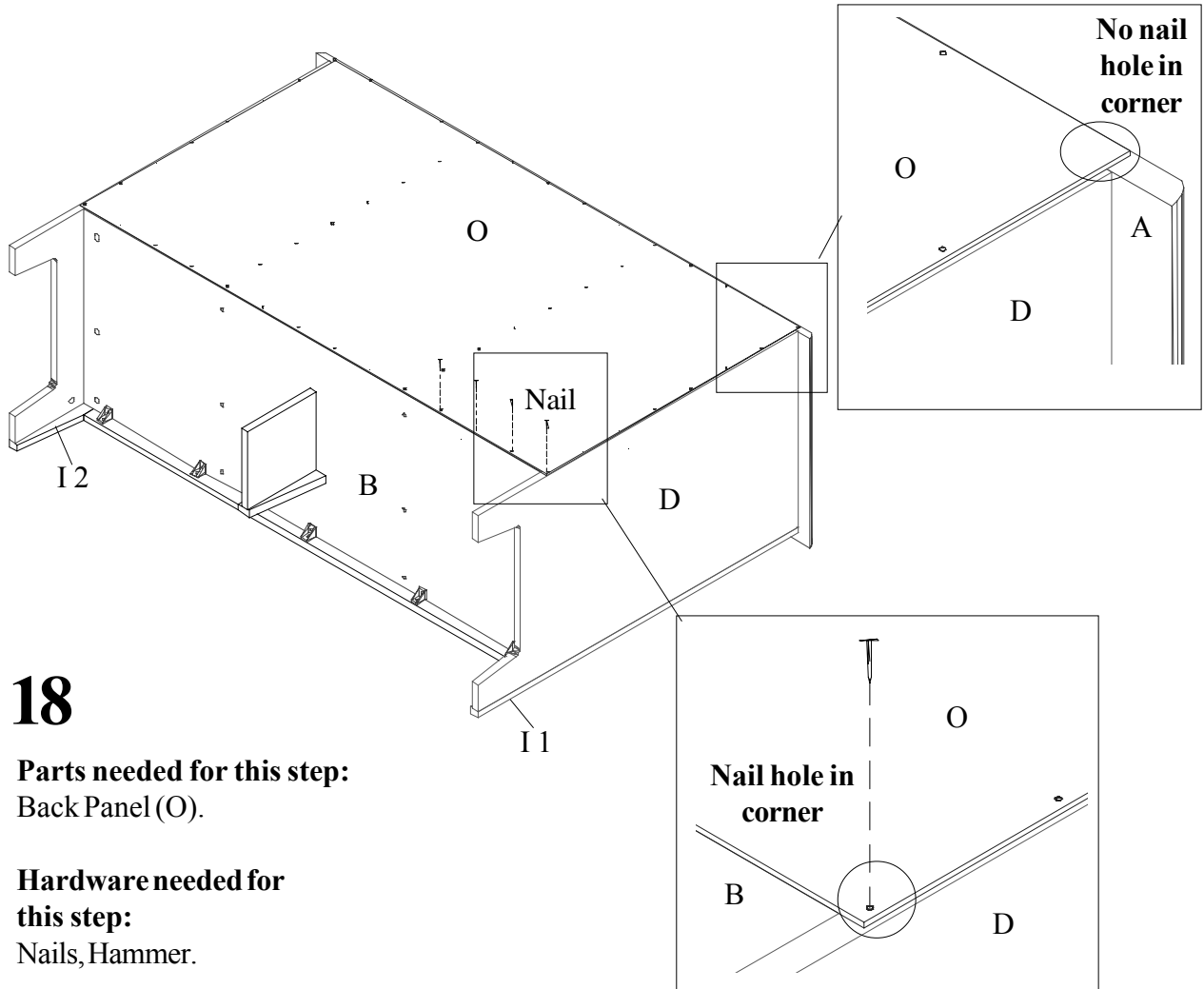

18

Parts needed for this step:
Back Panel (O).

Hardware needed for this step:
Nails, Hammer.

Action Required:

- * **Fold hinges in rails (I1 & I2) to prevent bending before placing unit on its front.**
- * With a helper, carefully turn unit over with the front against the floor.
- * Position back panel (O), **as shown in blow-ups**, flush with the bottom edge of bottom (B).
- * Make sure panel (O) fits square and even side to side. **If it doesn't, adjust unit into square by pushing or pulling on one corner of the unit until back panel fits squarely.**
- * Before nailing into pilot holes, make sure holes in back panel align with partitions (E & E1).

Note: Make sure all cam housings are in the locked position.

19

Parts needed for this step:

(4) Adjustable Shelves (F).

Hardware needed for this step:

(2) Magnetic Catches (MC), (16) Locking Shelf Pins (LPN).

Action Required:

* SEE HELPFUL HINT...

- Attach (2) magnetic catches (MC) to partitions (E & E1), using the small round-head screws provided in the small plastic bag.
- To install (4) adjustable shelves (F), push locking shelf pins (LPN) into the holes at the height you desire.
- Position the shelves so they rest on top of the locking shelf pins and push down to lock in place.

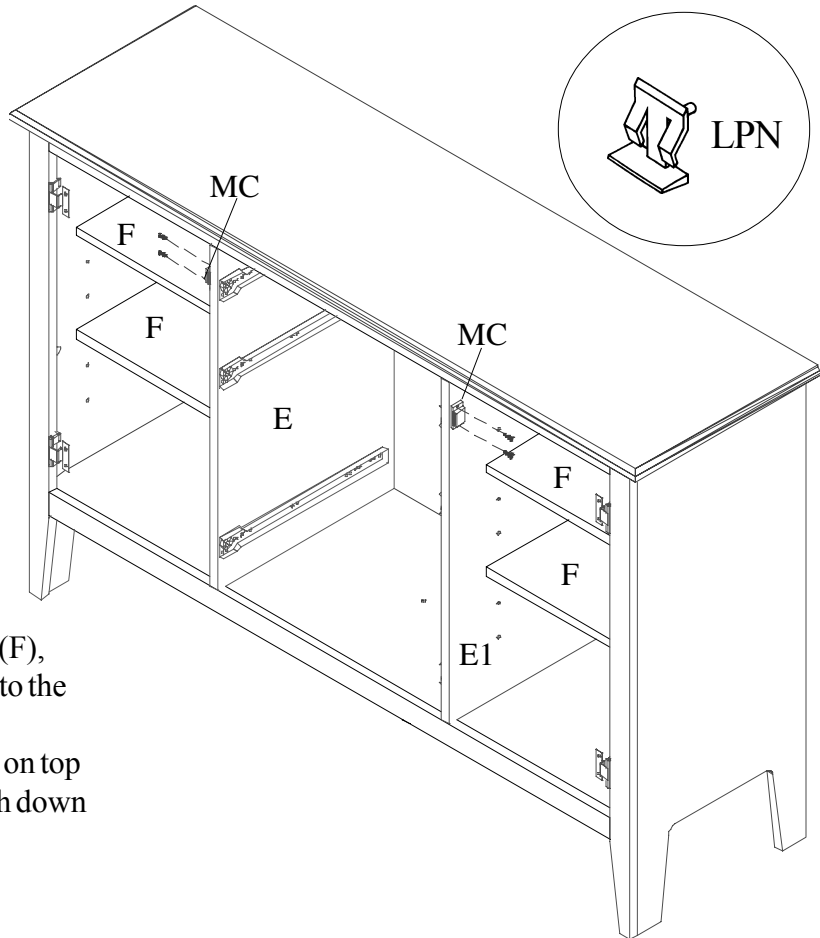

Helpful Hint

Magnets in magnetic catch sets (MC) should face the front of the unit. Slide magnetic catch (MC) as far as you can toward the front edge of partitions (E & E1) before tightening.

20

* Decorative cover caps are provided to cover exposed cam housings.

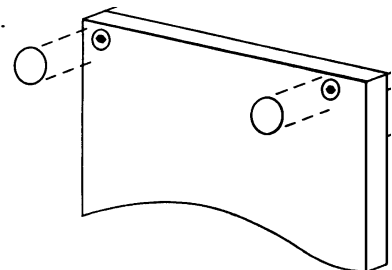

21

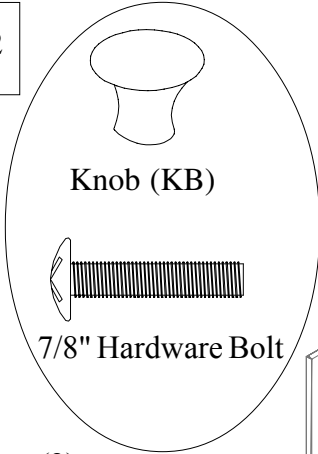
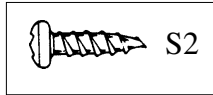

Parts needed for this step:
(2) Doors (H).

Hardware needed for this step:
(8) Round-Head Screws (S2), (2) Strike Plates (SP), (2) Knobs (KB), (2) 7/8" Hardware Bolts.

Action Required:

- * Attach doors (H) to rails (I1 & I2), using (2) screws (S2) in each hinge.
- * **Adjustment may be made to doors (H) by loosening screws in hinges, adjusting and retightening.**
- * Attach strike plates (SP) to doors (H), using the flat-head screws provided in the small plastic bag.
- * Attach knobs (KB) to doors (H), using (2) 7/8" hardware bolts.

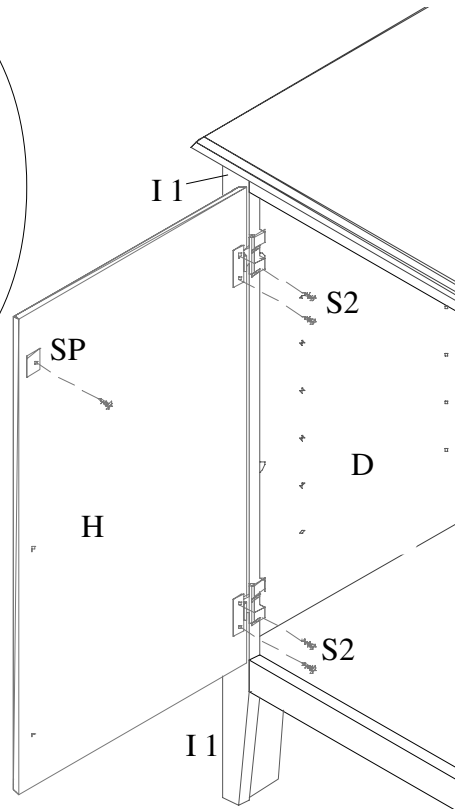

22

Install the drawers.

THIS UNIT HAS BEEN DESIGNED FOR THE WEIGHTS SHOWN. EXCEEDING THESE RECOMMENDED WEIGHTS COULD RESULT IN EXCESSIVE "SAGGING" OF THE SHELVES. EXTREME OVERLOADING COULD CAUSE FAILURE OF THE SHELVES AND POSSIBLE INJURY.

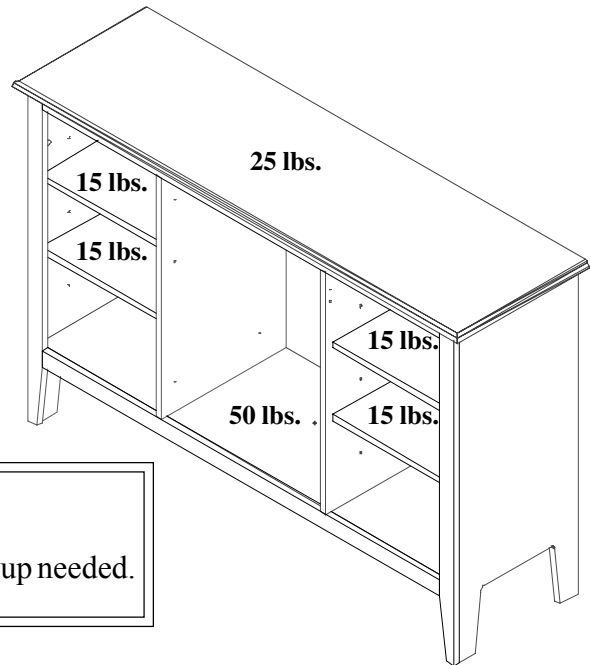



A **touch-up pen** has been provided for any touch up needed.

That's it! You've finished assembling your 3 Drawer / 2 Door Dresser.

MRP- 80115122 (Carysbrook)
1204