

Country Lane Two Shelf Wide Bookcase

Style # 563-105 (Pine) DPCI# 074-09-0696

Assembly Instructions (Carysbrook)

CONGRATULATIONS

You've purchased a fine furniture product by



All of our easy-to-assembly furniture is solidly built and rigorously tested to ensure years of enjoyment.

We're here to help. Just call **1-800-782-3876** or e-mail CISupport@Thomasville.com

BEFORE YOU BEGIN

You may find it helpful to have a helper while assembling unit. We've included easy to follow step-by-step instructions which have been carefully written to ensure quick, easy assembly of your furniture. Be sure to read the instructions (a time saver in the long run).

Identify all parts and hardware. If any pieces are missing call **Toll Free number 1-800-782-3876** or e-mail CISupport@Thomasville.com for replacement parts. For faster service, have the style number handy when calling.

Questions?

We're here to help. You may e-mail CISupport@Thomasville.com or call **1-800-782-3876** between 8:00a.m. - 9:00p.m., Monday - Friday and 9:00a.m. - 5:00p.m., Saturday (Eastern Time). Holiday weekends will not be staffed. For faster service, have the style number handy when calling.

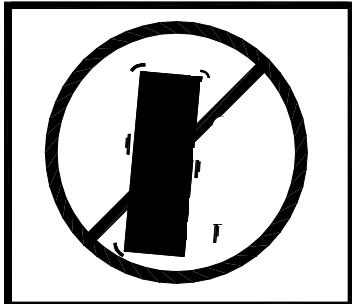

WARNING...This unit is to be used for its intended purpose. Other uses may cause product to tip.

- * Do not allow anyone to climb on unit.
- * Put heavy items on lower shelves.



Tools

You will need a standard flat-head screwdriver, Phillips head screwdriver and a hammer.

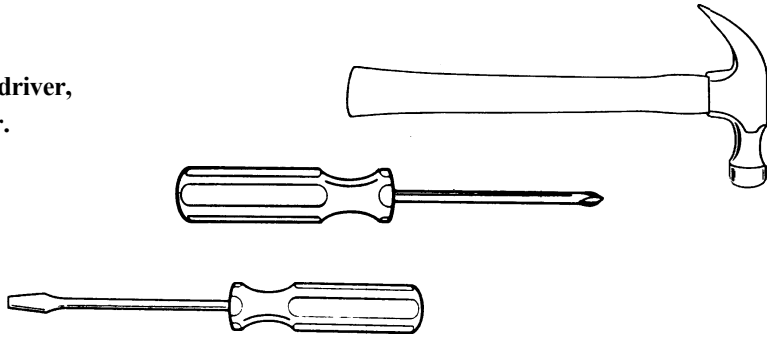

Parts List

Screws are shown actual size. Hardware may be shown smaller than actual size. Before you begin assembly, lay all pieces out on the floor according to these illustrations.

Note: For reasons of manufacturing efficiencies, you may find extra hardware and unused holes in parts.



S2 1/2" Phillips-head Screw (12)
002262

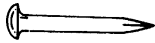

Nail (35)
002669



CS Long Cam Stud (8)
009612

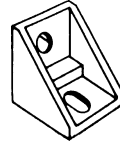

LB Plastic L-Bracket (6)
001136



Cover-cap (10)
80112983

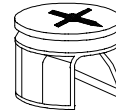

CH Cam Housing (12)
009613

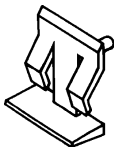

LPN Locking Shelf Pins (4)
004053



SCS Short Cam Stud (4)
009611

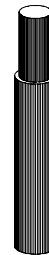

TP Touch-Up Pen (1)
80113188

Note: All parts may not be identified with labels, but to help identify certain parts, you may see one or more types of labelling. One type is the peel-off label and the other is an ink-print on one of the unfinished edges.

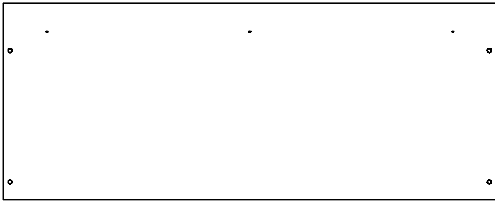

A Top (1)
33-1/16" x 13-3/16"
013308Z

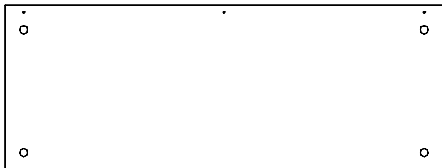

B Bottom (1)
31-1/2" x 11-3/4"
023202Z

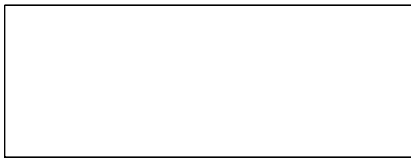

F Adjustable Shelf(1)
31-5/16" x 11-5/8"
063203Z

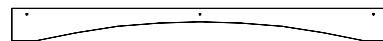
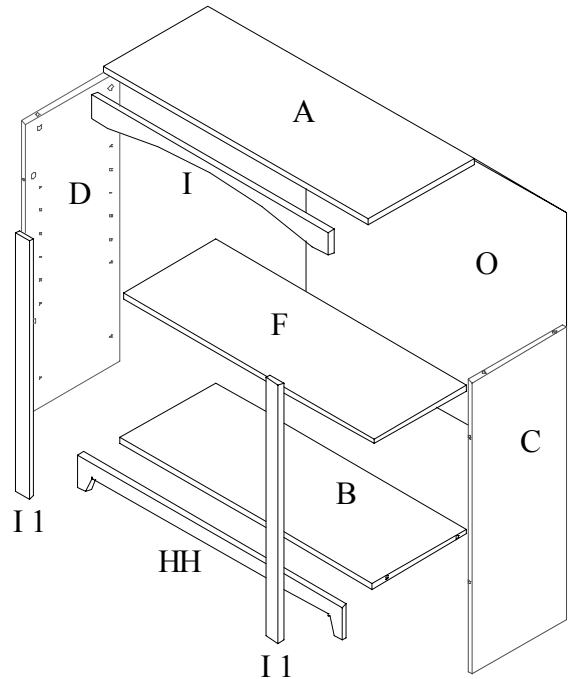

I Top Front Molding (1)
29-9/16" x 2-9/16"
092921Z

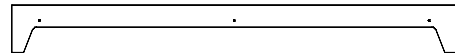

HH Bottom Front Molding (1)
32-15/16" x 3-9/16"
343305Z

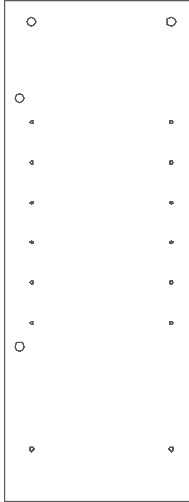

D Left Side (1)
31-1/2" x 11-3/4"
043201Z

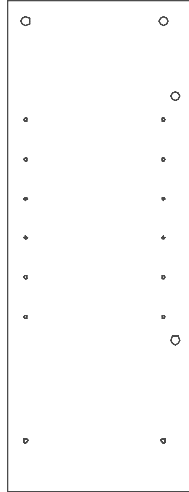

C Right Side (1)
31-1/2" x 11-3/4"
033201Z



I1 Vertical Rail (2)
27-13/16" x 1-5/8"
092803Z

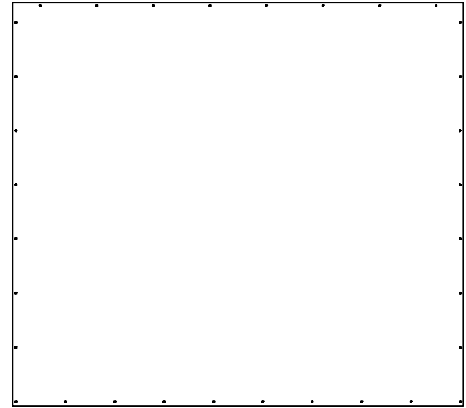

O Back Panel (1)
32-1/2" x 29-1/16"
80110993

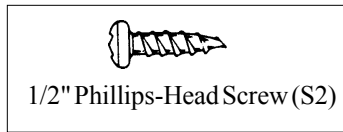

1

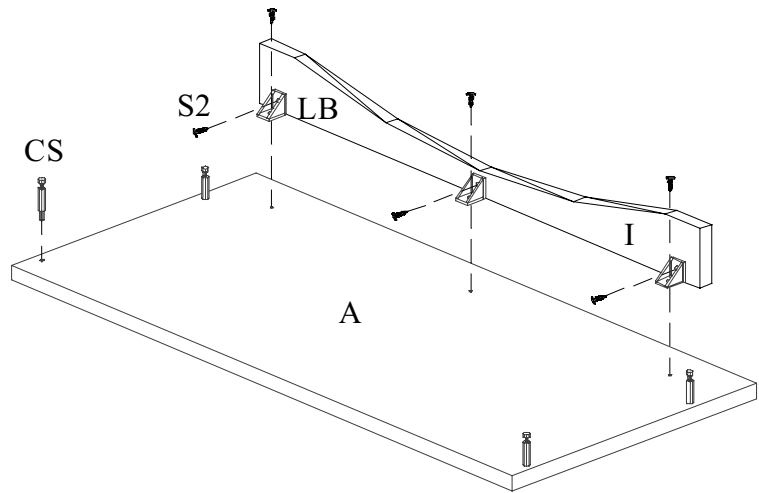
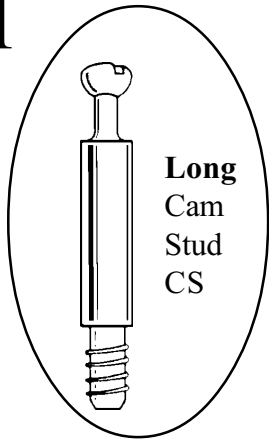

Parts needed for this step:
Top (A), Top Front Molding (I).

Hardware needed for this step:
(4) Long Cam Studs (CS), (3) L-Brackets (LB), (6) 1/2" Phillips-Head Screws (S2).

Action Required:

- * Screw (4) long cam studs (CS) into the holes, as shown, in top (A).
- * Attach (3) L-Brackets (LB) to top front molding (I), using (3) screws (S2).
- * **Loosely**, attach top front molding (I) to top (A), using (3) screws (S2).

2

Parts needed for this step:

Bottom (B), Bottom Front Molding (HH).

Hardware needed for this step:

- (4) Cam Housings (CH),
- (3) L-Brackets (LB),
- (6) 1/2" Phillips-Head Screws (S2).

Action Required:

- * **SEE FIGURE 1**...Insert (4) cam housings (CH) into the holes, as shown, in bottom (B). **Press with thumb to fully seat cam housings.**
- * Attach (3) L-Brackets (LB) to bottom (B), using (3) screws (S2).
- * **Loosely**, attach bottom front molding (HH) to bottom (B), using (3) screws (S2).

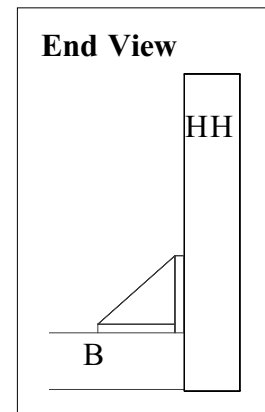
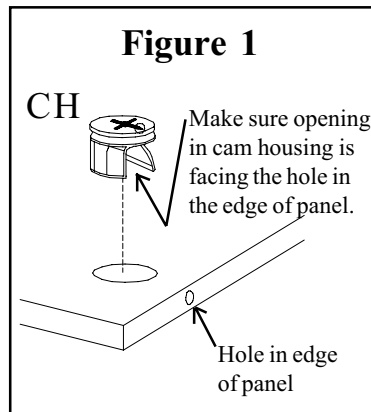
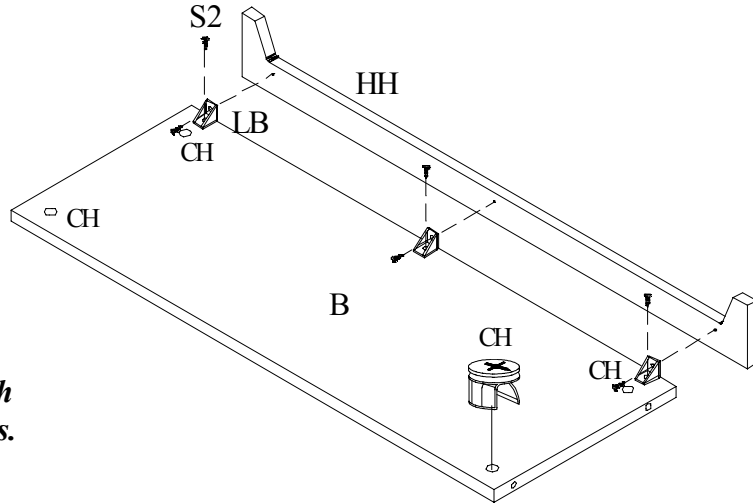
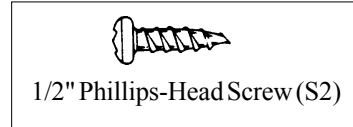

3

Parts needed for this step:

Left Side (D), Right Side (C).

Hardware needed for this step:

(8) Cam Housings (CH), (4) Long Cam Studs (CS).

Action Required:

- * Insert (8) cam housings (CH) into the holes, as shown, in left and right sides (D & C).
- * Screw (4) long cam studs (CS) into the holes, as shown, in left and right sides (D & C).

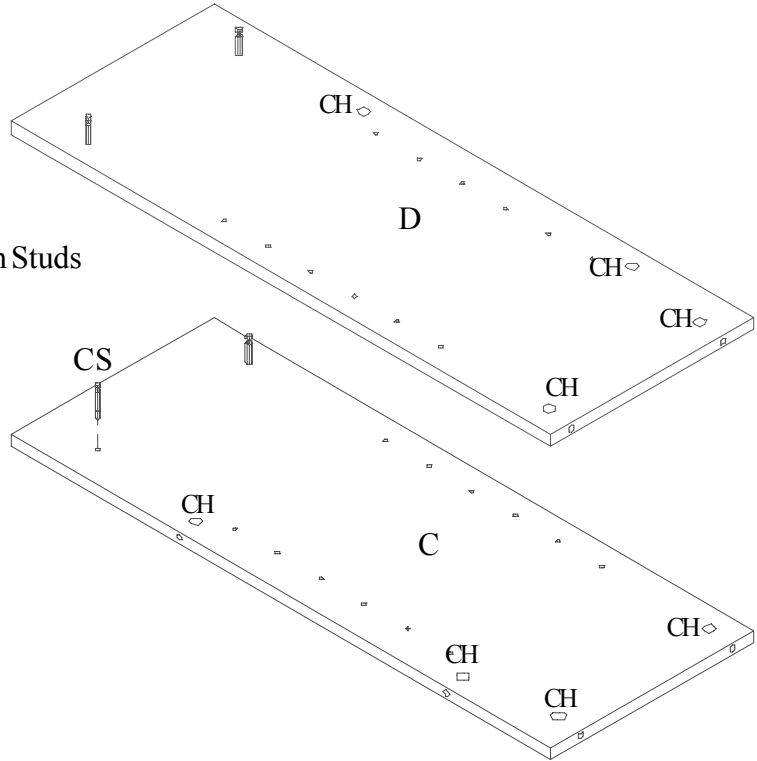

4

Parts needed for this step:

Left Side (D), Right Side (C),
Bottom (B).

Hardware needed for this step:

Standard Flat-Head Screwdriver.

Action Required:

- * Place left side (D) with cam housings up and facing to the inside of the case.
- * Attach bottom (B) to left side (D).
- * Lock cam housings with a half turn clockwise of a standard flat-head screwdriver.
- * Attach right side (C), with cam housings up and facing to the inside of the case, to bottom (B).
- * Lock cam housings.

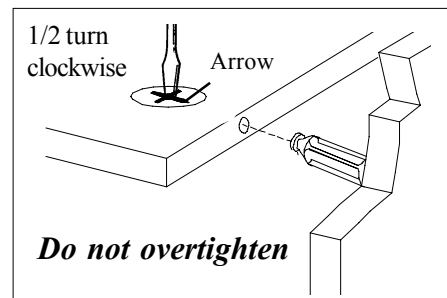
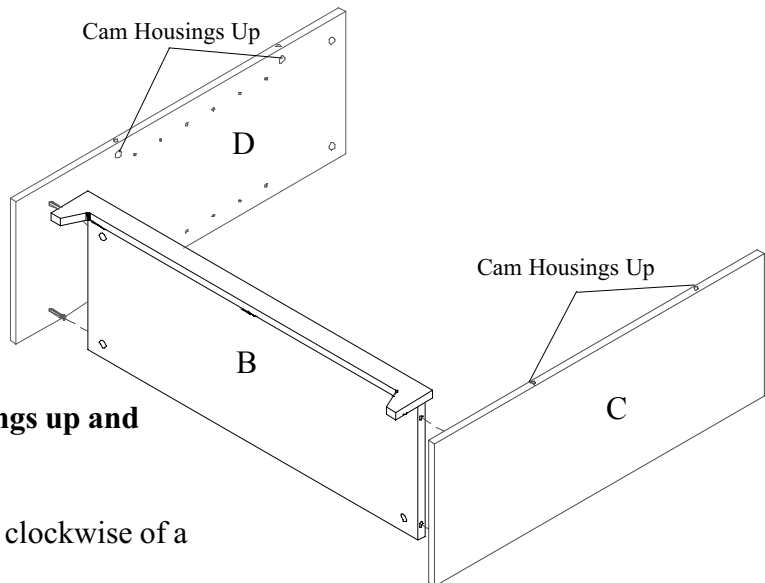

5

Parts needed for this step:

Top (A).

Hardware needed for this step:

Standard Flat-Head Screwdriver.

Action Required:

- * Attach top (A) to left and right sides (D & C)
- * Lock cam housings with a half turn clockwise of a standard flat-head screwdriver.

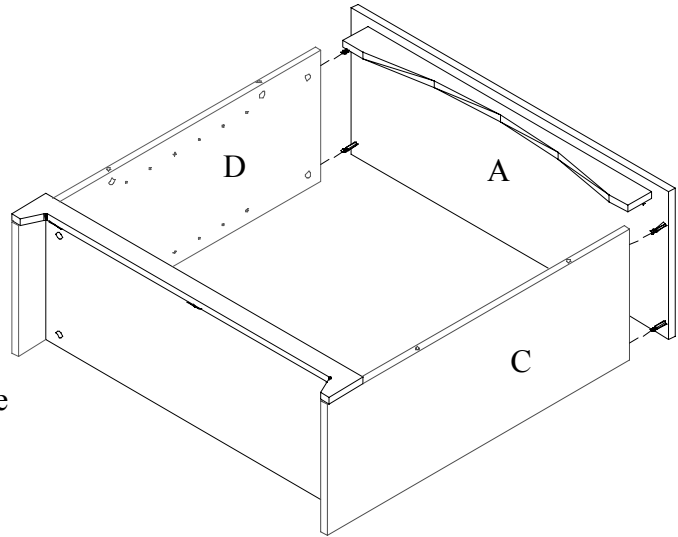

6

Parts needed for this step:

(2) Vertical Rails (I1).

Hardware needed for this step:

(4) Short Cam Studs (SCS).

Action Required:

- * Screw (4) short cam studs (SCS) into the holes, as shown, in vertical rails (I1).

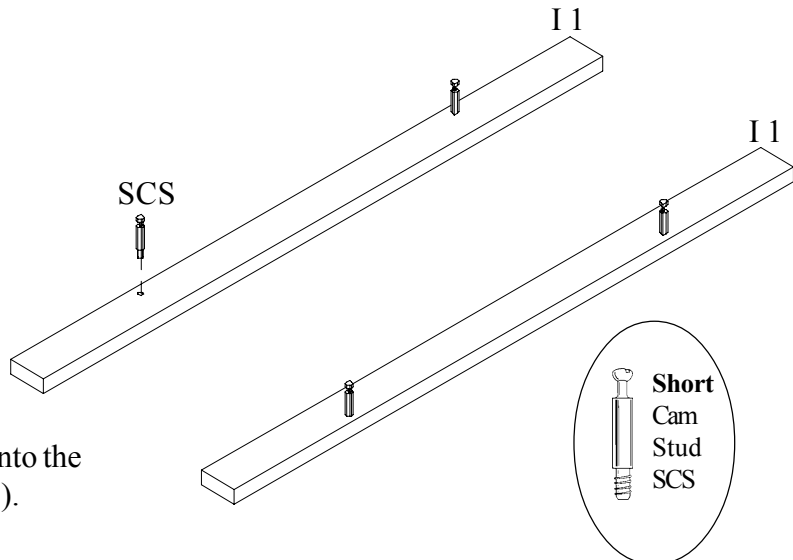

7

Parts needed for this step:

(2) Vertical Rails (I 1).

Hardware needed for this step:

Standard Flat-Head Screwdriver.

Action Required:

- * **SEE HELPFUL HINT...**Attach vertical rails (I 1) to left and right sides (D & C).
- * Lock cam housings.

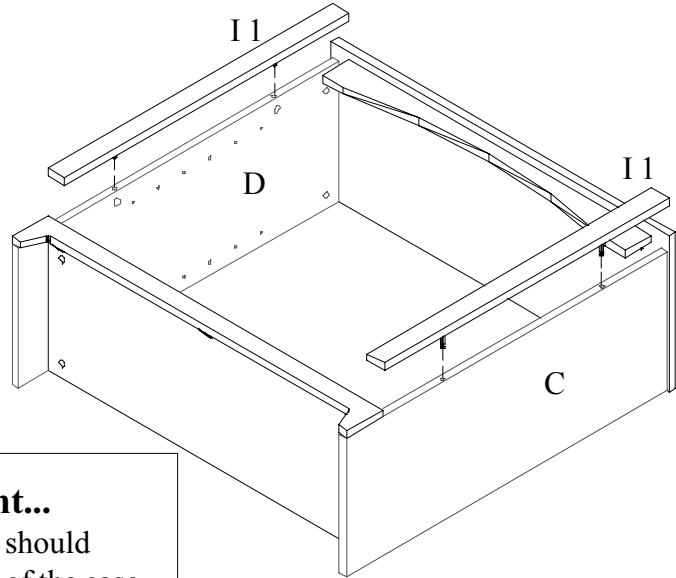

Helpful Hint...
Vertical rails (I 1) should overhang to the inside of the case.

8

Hardware needed for this step:

Phillips-Head Screwdriver.

Action Required:

- * Tighten screws in L-Brackets in top (A) and bottom (B).

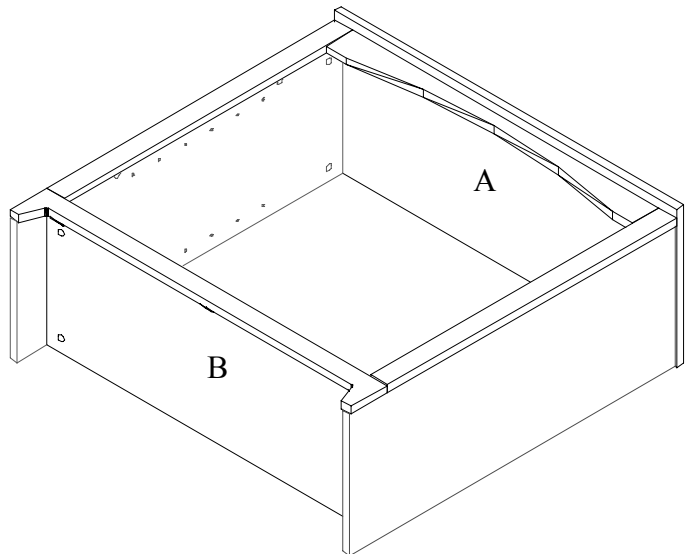

9

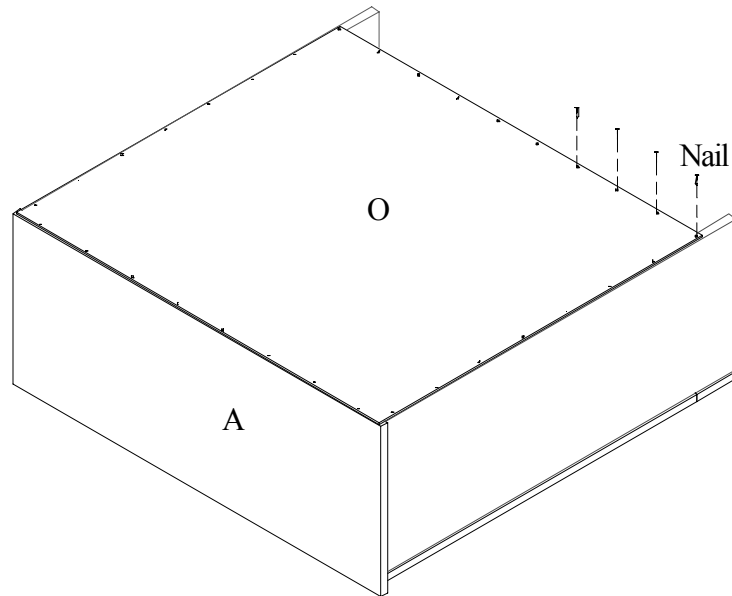

Note: Back panel adds stability to case.

Parts needed for this step:

Back Panel (O).

Hardware needed for this step:

Nails.

Action Required:

- * With a helper, carefully turn unit over with the front against the floor.
- * Position back panel (O), **finished side down**, even with the bottom edge of bottom (B).
- * Make sure panel (O) fits square and even side to side. **If it doesn't, adjust unit into square by pushing or pulling on one corner of the unit until back panel fits squarely.**
- * While nailing into pilot holes, take care to hammer nails in straight.

10

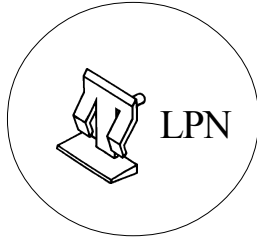

THIS UNIT HAS BEEN DESIGNED FOR THE WEIGHTS SHOWN. EXCEEDING THESE RECOMMENDED WEIGHTS COULD RESULT IN EXCESSIVE "SAGGING" OF THE PANELS. EXTREME OVERLOADING COULD CAUSE FAILURE OF THE PANEL AND POSSIBLE INJURY.

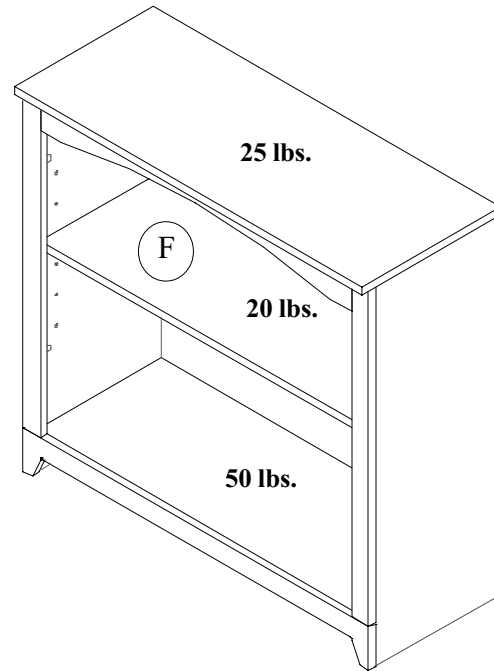

Parts needed for this step:

Adjustable Shelf (F).

Hardware needed for this step:

(4) Locking Shelf Pins (LPN).

Action Required:

- * To install adjustable shelf (F), push locking shelf pins (LPN) into the holes at the height you desire.
- * Position the shelf so it rests on top of the locking shelf pins and push down to lock in place.

Note: Make sure all cam housings are in the locked position.

11

* Decorative cover caps are provided to cover exposed cam housings.

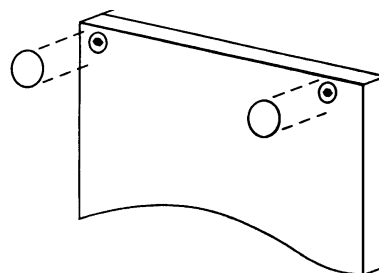

A touch-up pen has been provided for any touch up needed.

That's it! You've finished assembling your Two Shelf Wide Bookcase by



MRP- 80110991 (Carysbrook)
1004

Printed in United States of America